



**WYTWÓRNIA SPRZĘTU KOMUNIKACYJNEGO
„PZL – KROSNO” S.A.**

KATALOG CZĘŚCI ZAMIENNYCH

WYTWÓRNIA SPRZĘTU KOMUNIKACYJNEGO „PZL – KROSNO” S.A.

ul. Żwirki i Wigury 6
38-400 Krosno

telefon (+48 13) 43 74 301
fax: (+48 13) 43 688 61

http://
e-mail:

www.wsk-krosno.pl
wsk@wsk-krosno.pl

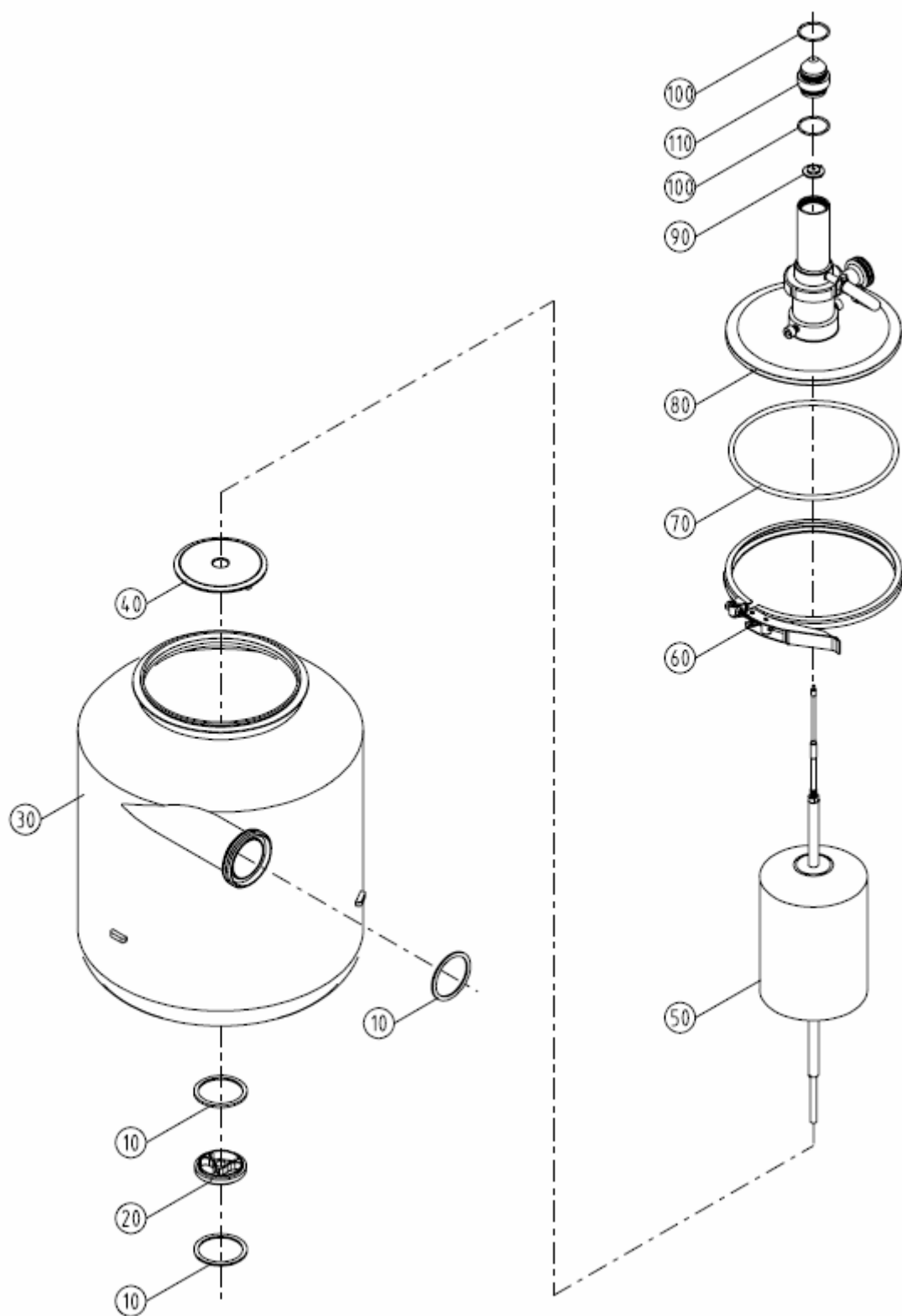

Separator powietrza

Nr rysunku:

Pozycja	Nazwa		Uwagi
10	Uszczelka DN65 DIN	Nr kat. 211	ARMAPOL
20	Rozeta	Nr kat 44A00858	WSK KROSNO
30	Zbiornik separatora	Nr kat 44A01993	WSK KROSNO
40	Tarcza centrująca pływaka	Nr kat 44A00171	WSK KROSNO
50	Zespół pływaka kompletny	Nr kat G0411005	WSK KROSNO
60	Obejma separatora	Nr kat G0411015	WSK KROSNO
70	Uszczelka pokrywy	Nr kat 44A00406	WSK KROSNO
80	Zespół pokrywy separatora kompletny	Nr kat G0411020	WSK KROSNO
90	Wskaźnik poziomu	Nr kat 44A00194	WSK KROSNO
100	O-ring 49x2,6		
110	Ręczny mechanizm mycia	Nr kat 44A03027	WSK KROSNO

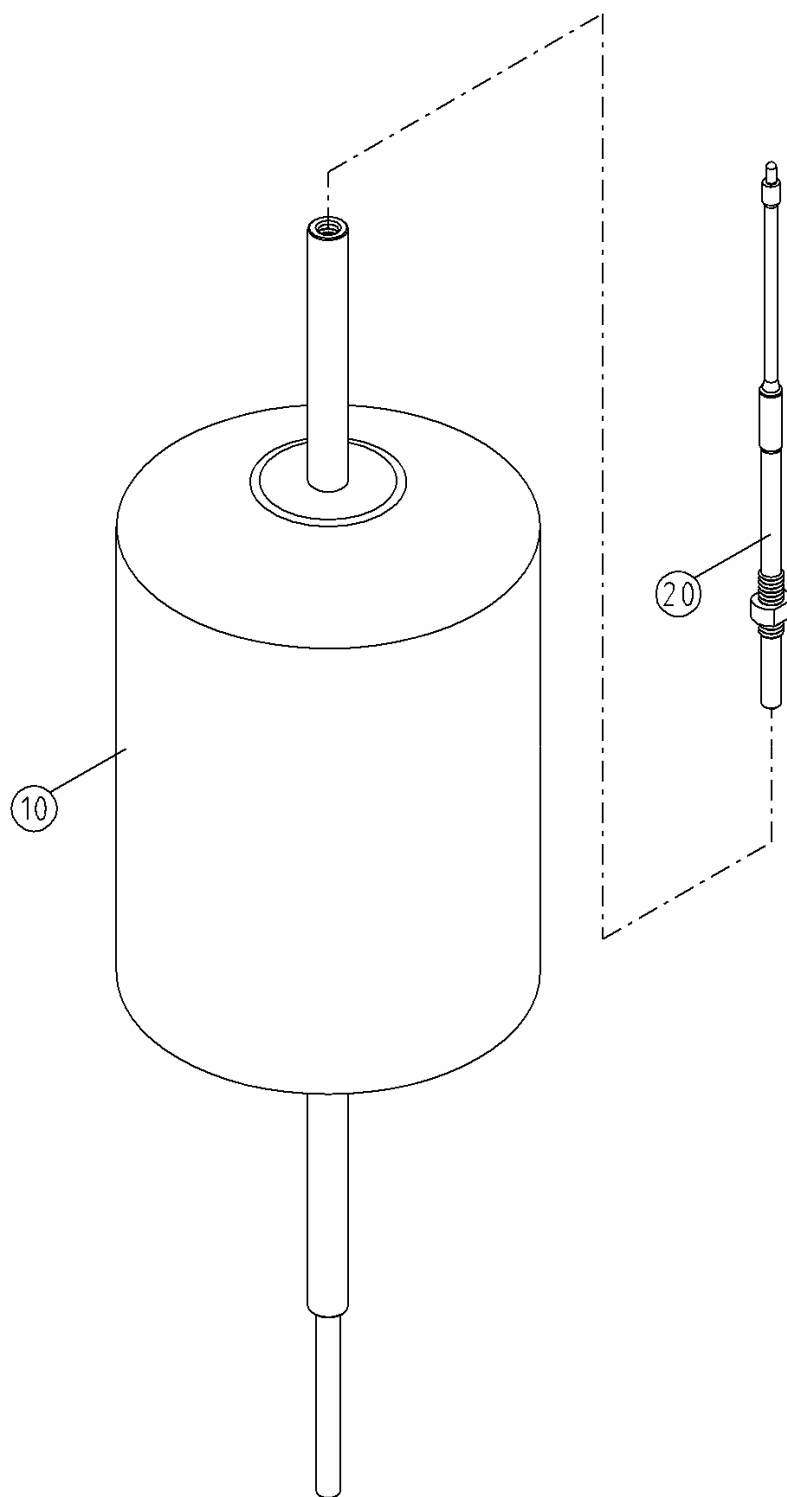

Pozycja	Nazwa		Uwagi
10	Pływak	Nr kat 44A00551	WSK KROSNO
20	Iglica separatora kompletna	Nr kat G0411010	WSK KROSNO



Pływak separatora

Nr rysunku:

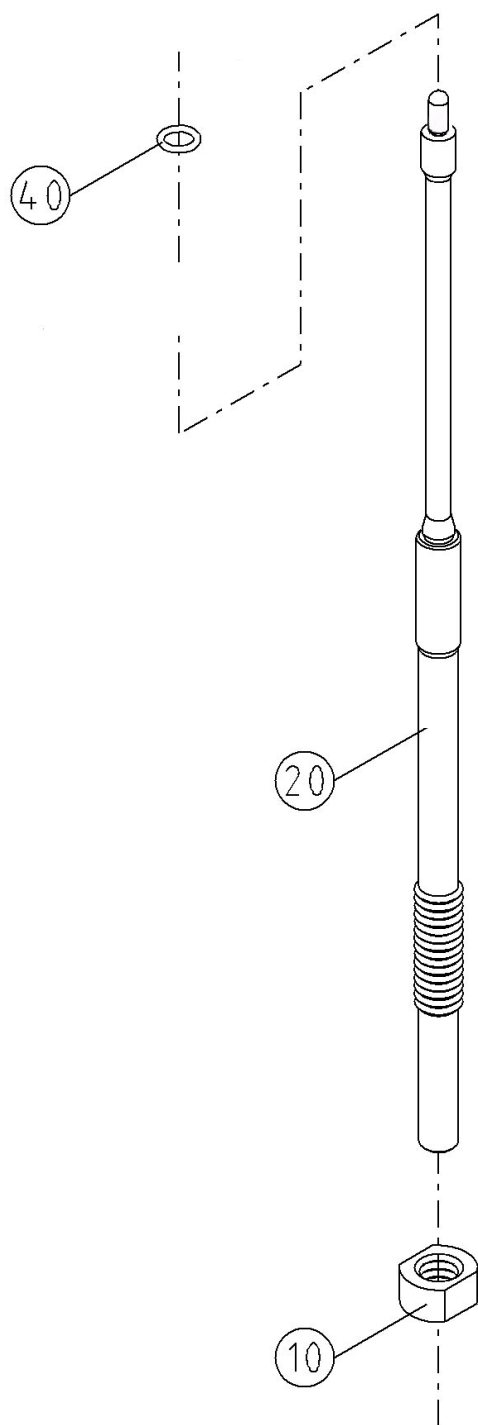

Pozycja	Nazwa		Uwagi
10	Nakrętka kontruująca	Nr kat 44A00185	WSK KROSNO
20	Iglica separatora	Nr kat 44A00183	WSK KROSNO
40	O-ring 5x1,5		



Iglica separatora

Nr rysunku:

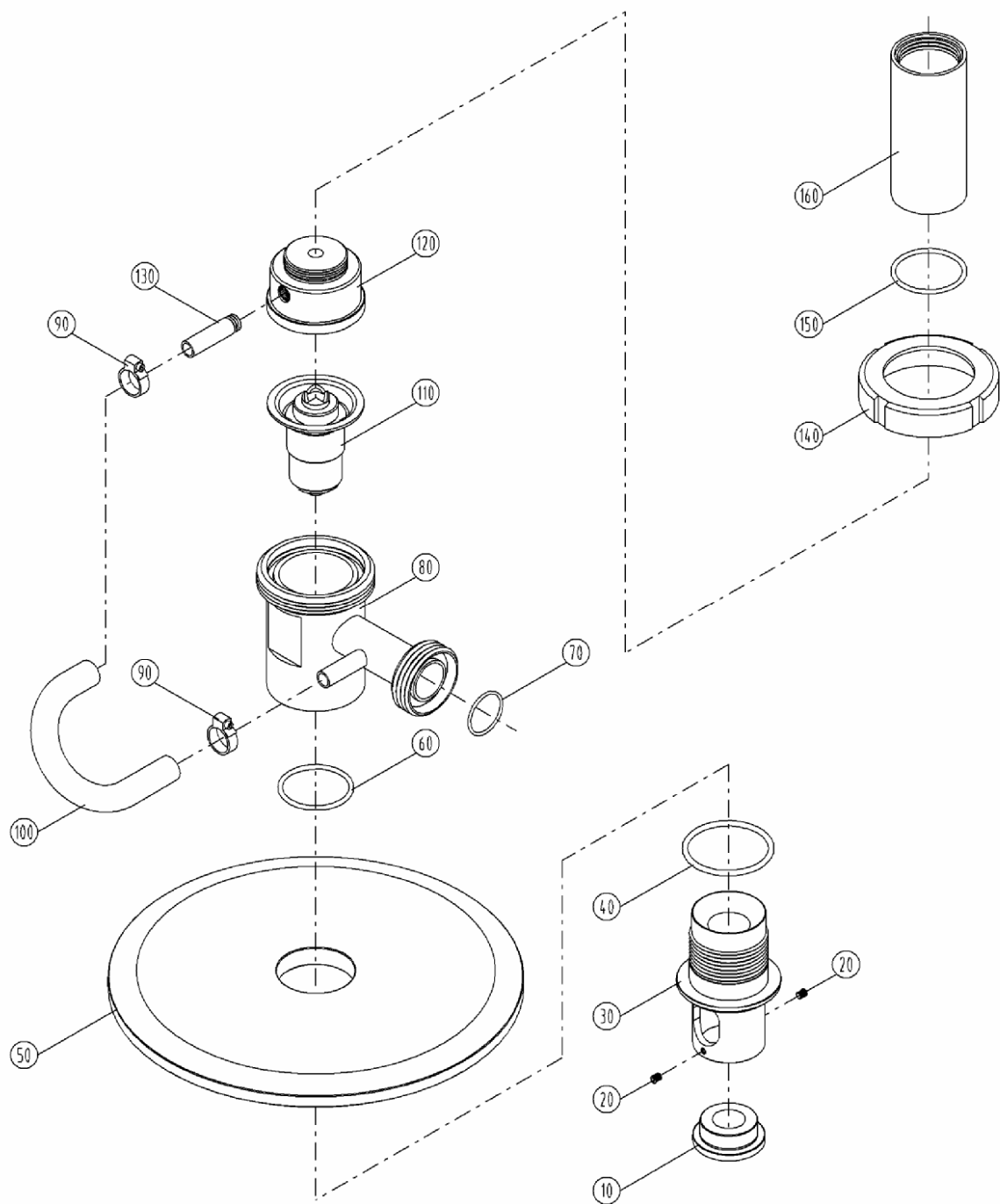

Pokrywa górna separatora

Nr rysunku:

Pozycja	Nazwa		Uwagi
10	Gniazdo pływaka	Nr kat 44A00193	WSK KROSNO
20	Wkręt bez łba M5x6	Nr kat 90100506	WSK KROSNO
30	Korpus dolny	Nr kat 44A03008	WSK KROSNO
40	O-ring 60x3,5		
50	Pokrywa	Nr Kat 44A00191	WSK KROSNO
60	O-ring 49x2,6		
70	Uszczelka DN25 DIN	Nr kat. 211	ARMAPOL
80	Korpus Górny	Nr kat. 44A00186	WSK KROSNO
90	Opaska zaciskowa 12-22/9 A2		
100	Wąż 10x16 zbrojony		
110	Tłoczek teflonowy kompletny	G0411025	WSK KROSNO
120	Pokrywa zaworu	Nr kat. 44A00190	WSK KROSNO
130	Rurka M12 L=45 0H18N9		
140	Nakrętka DN50 DIN	Nr kat. 210	ARMAPOL
150	O-ring 40x2,5		
160	Wziernik separatora	Nr kat. 44A00203	WSK KROSNO

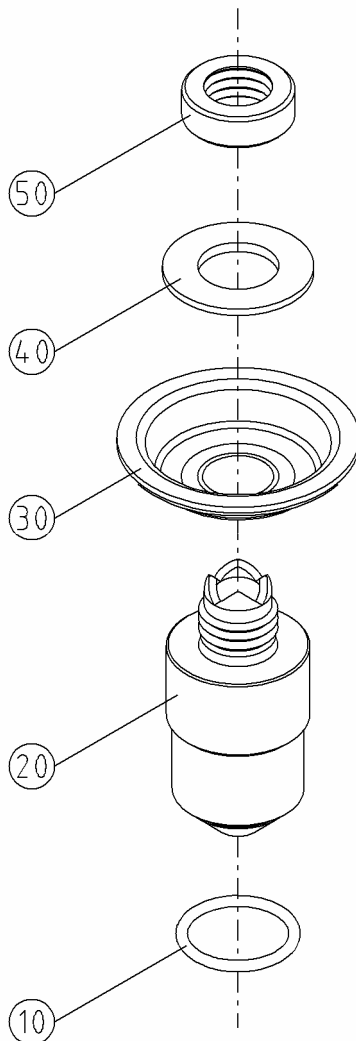

Pozycja	Nazwa		Uwagi
10	O-ring tłoczka 25x3		
20	Tłoczek teflonowy	Nr Kat 44A00195	WSK KROSNO
30	Membrana separatora 50x40x10	Nr kat. 53000520	WSK KROSNO
40	Podkładka tłoczka	Nr kat. 44A00196	WSK KROSNO
50	Nakrętka tłoczka	Nr kat. 44A00197	WSK KROSNO



Zawór 2 fazowy

Nr rysunku:

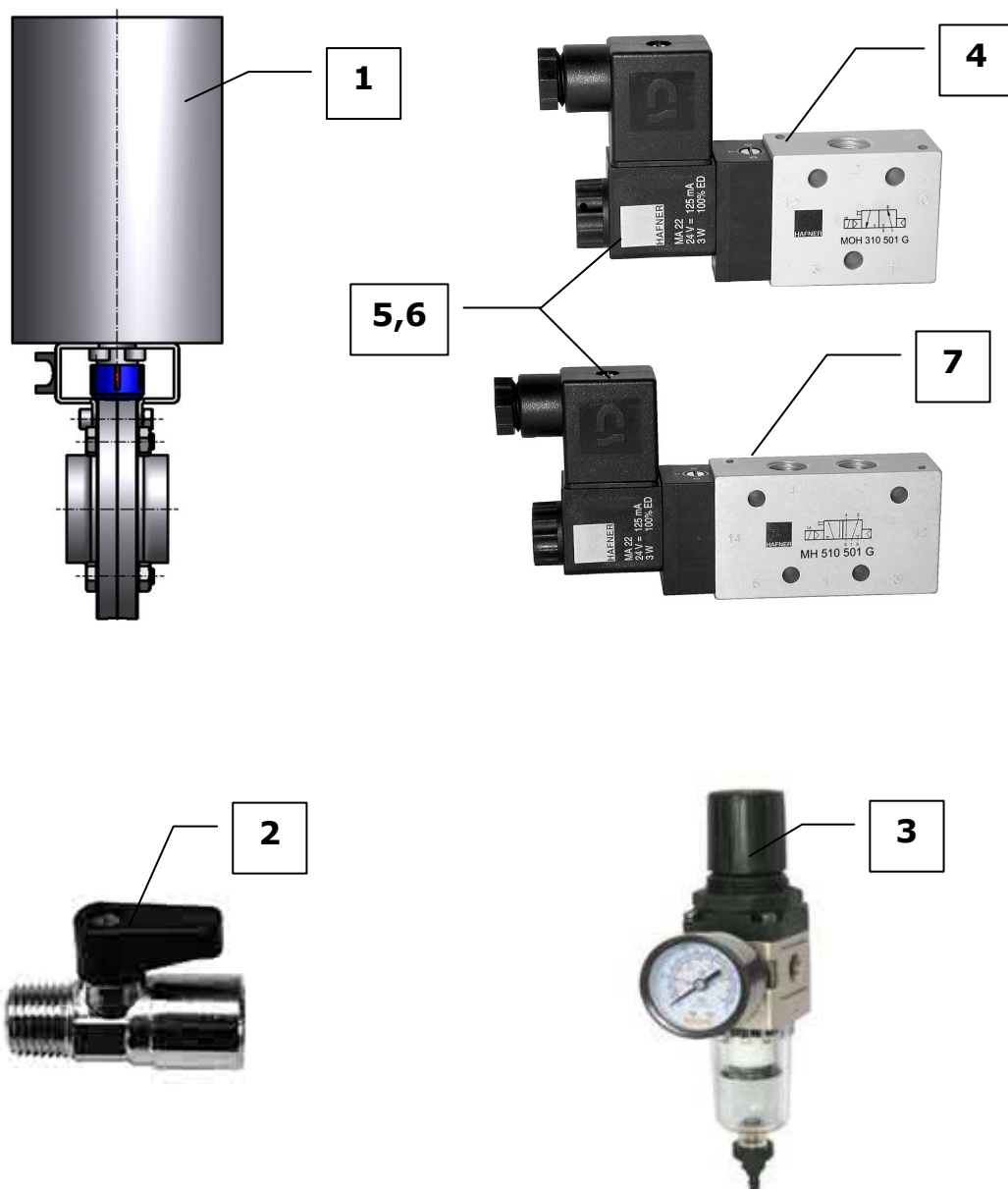

Pozycja	Nazwa		Uwagi
1	Siłownik PAMS2010 rozmiar 0		
2	Zawór odcinający		
3	FILTR REDUKCYJNY G1/4"		
4	Zawór 3/2 1/8"		
5	Cewka 24 V DC		
6	Wtyczka LED 24 V		
7	Zawór 5/2 1/8"		

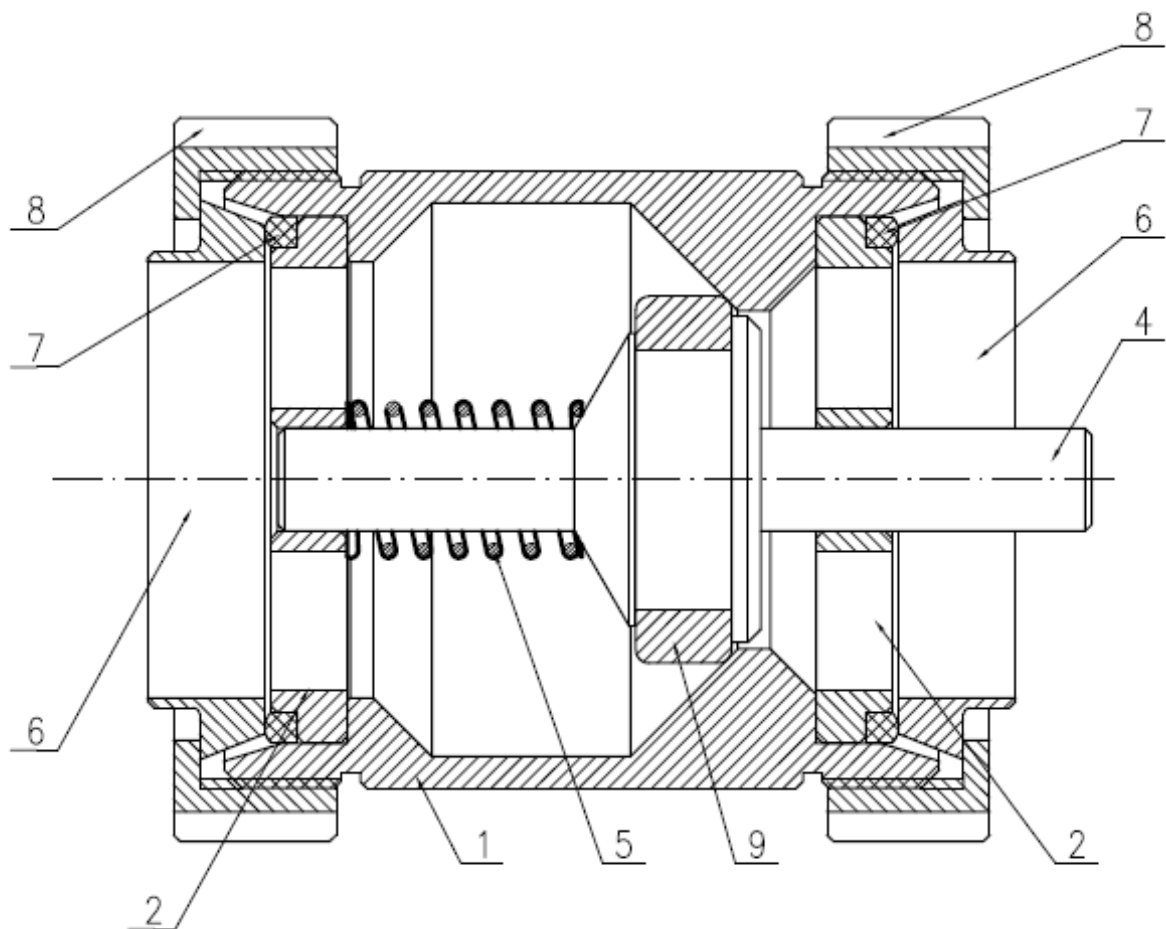

Pozycja	Nazwa		Uwagi
1	Korpus	CWU.509.01.0	WSK KROSNO
2	Rozeta zaworu	CWU.509.02.0	WSK KROSNO
4	Tłoczek zaworu	CWU.509.04.0	WSK KROSNO
5	Sprężyna	C240.225.0550.I	VANEL
6	Pierścień redukcyjny DN 65/50 DIN	1.4301	
7	Uszczelka DN65 DIN		
8	Nakrętka DN65 DIN	1.4301	
9	Uszczelnienie		WSK Krosno



**Zawór zwrotny
WSK Krosno**

Nr rysunku:

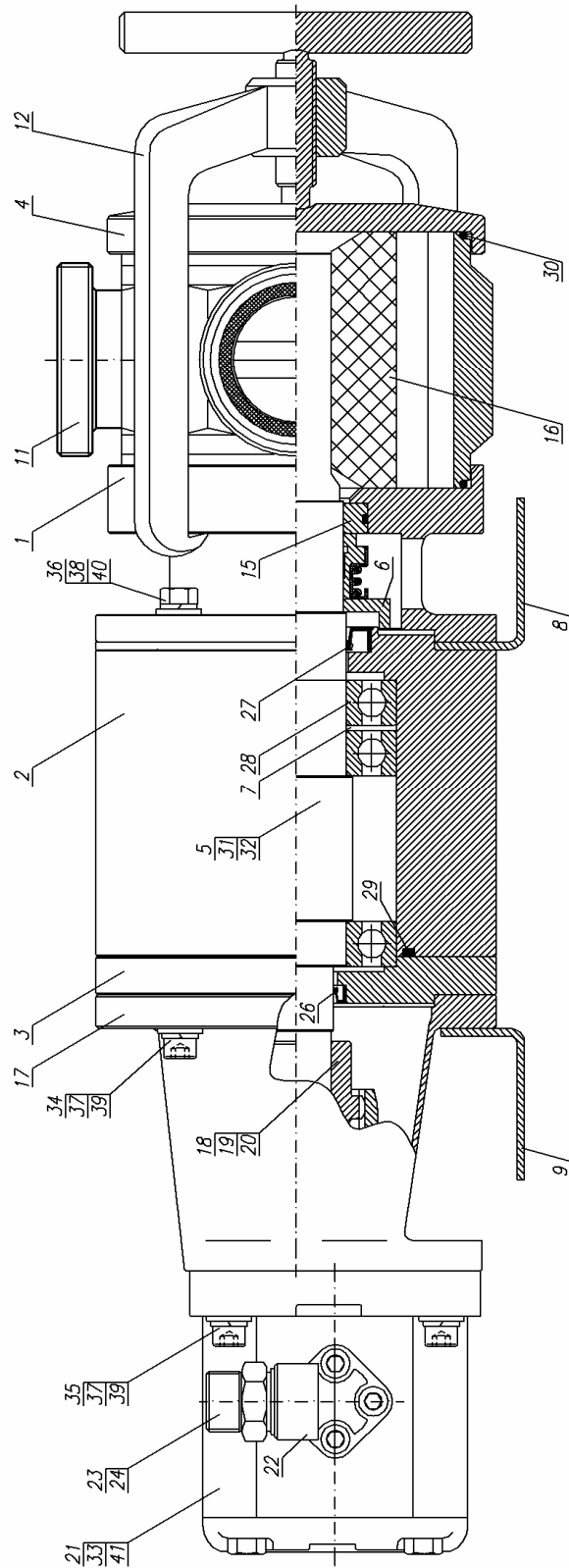

Pompa mleka PM24

Nr rysunku:

42					
41	Podkładka sprężysta 12,2	PN-77/M-82008	1	Fe/Zn	
40	Podkładka sprężysta 8,2	PN-77/M-82008	4	A2	
39	Podkładka sprężysta 8,2	PN-77/M-82008	8	Fe/Zn	
38	Podkładka 8,5	PN-78/M-82005	4	A2	
37	Podkładka 8,5	PN-78/M-82005	8	Fe/Zn	
36	Sruba z łbem sześciokątnym M8x25	PN-85/M-82105	4	A2-70	
35	Sruba z łbem walcowym z gniazdem sześciokątnym M8x30-8,8	PN-87/M-82302	4	Fe/Zn	
34	Sruba z łbem walcowym z gniazdem sześciokątnym M8x45-8,8	PN-87/M-82302	4	Fe/Zn	
33	Nakrętka niska M12x1,25-8	PN-86/M-82153	1	Fe/Zn	
32	Wpust czułekowy 4x6,5	PN-73/M-85008	1		
31	Wpust pryzmatyczny A8x7x20	PN-70/M-85005	1		
30	O-ring 129,77x3,53	PN-68/H-74378	2	VMQ lub MVQ	
29	O-ring 88,5x3,53	PN-68/H-74378	1		
28	Łożysko kulkowe 6208-2RS	PN-85/M-86100	3		
27	Uszczelniacz 60x40x10	PN-72/M-86964	1		
26	Uszczelniacz 40x30x7	PN-72/M-86964	1		
25					
24	Korpus przyłączy prostej M24x1,5/G1/2	PN-65/M-73125	2		
23	Uszczelka metalowo-gumowa 26,7x21,65x1,25	art. handlowy	2		
22	Kolnierz z oringiem 90° cynkowany	WDS 2 12	2		
21	Silnik hydrauliczny	SEM2	1		
20	Tuleja BoWex	M-28	1		
19	Piasta BoWex	M-28	1		
18	Piasta BoWex	M-28	1		
17	Łącznik	PL 160/4/3	1		
16	Wirmik gumowy z wkładką metalową	JO-24	1		
15	Uszczelnienie kpl A=29,7	HKH-038	1		
14					
13					
12	Docisk	PM24.020.00.0	1		
11	Korpus	PM24.010.00.0	1		
10					
9	Stopa tylna	PM24.000.09.0	1		
8	Stopa przednia	PM24.000.08.0	1		
7	Dystans	PM24.000.07.0	1		
6	Pierścień	PM24.000.06.0	1		
5	Wał	PM24.000.05.0	1		
4	Dekiel	PM24.000.04.0	1		
3	Pokrywa piasty	PM24.000.03.0	1		
2	Piasta	PM24.000.02.0	1		
	Łącznik	PM24.000.01.0	1		
		Nr rys. lub normy	Ilość szt.	Material	

do			Chropowalac	Form. ogólna	IT14	Nr archiwalny	Wyrób	Nr ark./licz ark
			Zrobka cieplna	Podzielnik	1:2		PM24	1/1
			Powloki ochr.	Szl./wyrób	1	Zastępuje rys:		
			Masa	Format	A2	Zastąpiony przez:		
			Material i oszrobment					
Stanowisko	Nazwisko	Data i podpis	<div style="display: flex; align-items: center;"> <div style="border: 1px solid black; padding: 2px; margin-right: 5px;">W</div> <div style="border: 1px solid black; padding: 2px; margin-right: 5px;">S</div> <div style="border: 1px solid black; padding: 2px; margin-right: 5px;">K</div> <div style="border: 1px solid black; padding: 2px; margin-right: 5px;">R</div> <div style="border: 1px solid black; padding: 2px; margin-right: 5px;">O</div> <div style="border: 1px solid black; padding: 2px; margin-right: 5px;">S</div> <div style="border: 1px solid black; padding: 2px; margin-right: 5px;">K</div> <div style="border: 1px solid black; padding: 2px; margin-right: 5px;">R</div> <div style="border: 1px solid black; padding: 2px; margin-right: 5px;">O</div> <div style="border: 1px solid black; padding: 2px; margin-right: 5px;">S</div> <div style="border: 1px solid black; padding: 2px; margin-right: 5px;">K</div> <div style="border: 1px solid black; padding: 2px; margin-right: 5px;">R</div> <div style="border: 1px solid black; padding: 2px; margin-right: 5px;">O</div> <div style="border: 1px solid black; padding: 2px; margin-right: 5px;">S</div> <div style="border: 1px solid black; padding: 2px; margin-right: 5px;">K</div> <div style="border: 1px solid black; padding: 2px; margin-right: 5px;">R</div> <div style="border: 1px solid black; padding: 2px; margin-right: 5px;">O</div> <div style="border: 1px solid black; padding: 2px; margin-right: 5px;">S</div> <div style="border: 1px solid black; padding: 2px; margin-right: 5px;">K</div> <div style="border: 1px solid black; padding: 2px; margin-right: 5px;">R</div> <div style="border: 1px solid black; padding: 2px; margin-right: 5px;">O</div> <div style="border: 1px solid black; padding: 2px; margin-right: 5px;">S</div> <div style="border: 1px solid black; padding: 2px; margin-right: 5px;">K</div> <div style="border: 1px solid black; padding: 2px; margin-right: 5px;">R</div> <div style="border: 1px solid black; padding: 2px; margin-right: 5px;">O</div> <div style="border: 1px solid black; padding: 2px; margin-right: 5px;">S</div> <div style="border: 1px solid black; padding: 2px; margin-right: 5px;">K</div> <div style="border: 1px solid black; padding: 2px; margin-right: 5px;">R</div> <div style="border: 1px solid black; padding: 2px; margin-right: 5px;">O</div> <div style="border: 1px solid black; padding: 2px; margin-right: 5px;">S</div> <div style="border: 1px solid black; padding: 2px; margin-right: 5px;">K</div> <div style="border: 1px solid black; padding: 2px; margin-right: 5px;">R</div> <div style="border: 1px solid black; padding: 2px; margin-right: 5px;">O</div> <div style="border: 1px solid black; padding: 2px; margin-right: 5px;">S</div> <div style="border: 1px solid black; padding: 2px; margin-right: 5px;">K</div> <div style="border: 1px solid black; padding: 2px; margin-right: 5px;">R</div> <div style="border: 1px solid black; padding: 2px; margin-right: 5px;">O</div> <div style="border: 1px solid black; padding: 2px; margin-right: 5px;">S</div> <div style="border: 1px solid black; padding: 2px; margin-right: 5px;">K</div> <div style="border: 1px solid black; padding: 2px; margin-right: 5px;">R</div> <div style="border: 1px solid black; padding: 2px; margin-right: 5px;">O</div> <div style="border: 1px solid black; padding: 2px; margin-right: 5px;">S</div> <div style="border: 1px solid black; padding: 2px; margin-right: 5px;">K</div> <div style="border: 1px solid black; padding: 2px; margin-right: 5px;">R</div> <div style="border: 1px solid black; padding: 2px; margin-right: 5px;">O</div> <div style="border: 1px solid black; padding: 2px; margin-right: 5px;">S</div> <div style="border: 1px solid black; padding: 2px; margin-right: 5px;">K</div> <div style="border: 1px solid black; padding: 2px; margin-right: 5px;">R</div> <div style="border: 1px solid black; padding: 2px; margin-right: 5px;">O</div> <div style="border: 1px solid black; padding: 2px; margin-right: 5px;">S</div> <div style="border: 1px solid black; padding: 2px; margin-right: 5px;">K</div> <div style="border: 1px solid black; padding: 2px; margin-right: 5px;">R</div> <div style="border: 1px solid black; padding: 2px; margin-right: 5px;">O</div> <div style="border: 1px solid black; padding: 2px; margin-right: 5px;">S</div> <div style="border: 1px solid black; padding: 2px; margin-right: 5px;">K</div> <div style="border: 1px solid black; padding: 2px; margin-right: 5px;">R</div> <div style="border: 1px solid black; padding: 2px; margin-right: 5px;">O</div> <div style="border: 1px solid black; padding: 2px; margin-right: 5px;">S</div> <div style="border: 1px solid black; padding: 2px; margin-right: 5px;">K</div> <div style="border: 1px solid black; padding: 2px; margin-right: 5px;">R</div> <div style="border: 1px solid black; padding: 2px; margin-right: 5px;">O</div> <div style="border: 1px solid black; padding: 2px; margin-right: 5px;">S</div> <div style="border: 1px solid black; padding: 2px; margin-right: 5px;">K</div> <div style="border: 1px solid black; padding: 2px; margin-right: 5px;">R</div> <div style="border: 1px solid black; padding: 2px; margin-right: 5px;">O</div> <div style="border: 1px solid black; padding: 2px; margin-right: 5px;">S</div> <div style="border: 1px solid black; padding: 2px; margin-right: 5px;">K</div> <div style="border: 1px solid black; padding: 2px; margin-right: 5px;">R</div> <div style="border: 1px solid black; padding: 2px; margin-right: 5px;">O</div> <div style="border: 1px solid black; padding: 2px; margin-right: 5px;">S</div> <div style="border: 1px solid black; padding: 2px; margin-right: 5px;">K</div> <div style="border: 1px solid black; padding: 2px; margin-right: 5px;">R</div> <div style="border: 1px solid black; padding: 2px; margin-right: 5px;">O</div> <div style="border: 1px solid black; padding: 2px; margin-right: 5px;">S</div> <div style="border: 1px solid black; padding: 2px; margin-right: 5px;">K</div> <div style="border: 1px solid black; padding: 2px; margin-right: 5px;">R</div> <div style="border: 1px solid black; padding: 2px; margin-right: 5px;">O</div> <div style="border: 1px solid black; padding: 2px; margin-right: 5px;">S</div> <div style="border: 1px solid black; padding: 2px; margin-right: 5px;">K</div> <div style="border: 1px solid black; padding: 2px; margin-right: 5px;">R</div> <div style="border: 1px solid black; padding: 2px; margin-right: 5px;">O</div> <div style="border: 1px solid black; padding: 2px; margin-right: 5px;">S</div> <div style="border: 1px solid black; padding: 2px; margin-right: 5px;">K</div> <div style="border: 1px solid black; padding: 2px; margin-right: 5px;">R</div> <div style="border: 1px solid black; padding: 2px; margin-right: 5px;">O</div> <div style="border: 1px solid black; padding: 2px; margin-right: 5px;">S</div> <div style="border: 1px solid black; padding: 2px; margin-right: 5px;">K</div> <div style="border: 1px solid black; padding: 2px; margin-right: 5px;">R</div> <div style="border: 1px solid black; padding: 2px; margin-right: 5px;">O</div> <div style="border: 1px solid black; padding: 2px; margin-right: 5px;">S</div> <div style="border: 1px solid black; padding: 2px; margin-right: 5px;">K</div> <div style="border: 1px solid black; padding: 2px; margin-right: 5px;">R</div> <div style="border: 1px solid black; padding: 2px; margin-right: 5px;">O</div> <div style="border: 1px solid black; padding: 2px; margin-right: 5px;">S</div> <div style="border: 1px solid black; padding: 2px; margin-right: 5px;">K</div> <div style="border: 1px solid black; padding: 2px; margin-right: 5px;">R</div> <div style="border: 1px solid black; padding: 2px; margin-right: 5px;">O</div> <div style="border: 1px solid black; padding: 2px; margin-right: 5px;">S</div> <div style="border: 1px solid black; padding: 2px; margin-right: 5px;">K</div> <div style="border: 1px solid black; padding: 2px; margin-right: 5px;">R</div> <div style="border: 1px solid black; padding: 2px; margin-right: 5px;">O</div> <div style="border: 1px solid black; padding: 2px; margin-right: 5px;">S</div> <div style="border: 1px solid black; padding: 2px; margin-right: 5px;">K</div> <div style="border: 1px solid black; padding: 2px; margin-right: 5px;">R</div> <div style="border: 1px solid black; padding: 2px; margin-right: 5px;">O</div> <div style="border: 1px solid black; padding: 2px; margin-right: 5px;">S</div> <div style="border: 1px solid black; padding: 2px; margin-right: 5px;">K</div> <div style="border: 1px solid black; padding: 2px; margin-right: 5px;">R</div> <div style="border: 1px solid black; padding: 2px; margin-right: 5px;">O</div> <div style="border: 1px solid black; padding: 2px; margin-right: 5px;">S</div> <div style="border: 1px solid black; padding: 2px; margin-right: 5px;">K</div> <div style="border: 1px solid black; padding: 2px; margin-right: 5px;">R</div> <div style="border: 1px solid black; padding: 2px; margin-right: 5px;">O</div> <div style="border: 1px solid black; padding: 2px; margin-right: 5px;">S</div> <div style="border: 1px solid black; padding: 2px; margin-right: 5px;">K</div> <div style="border: 1px solid black; padding: 2px; margin-right: 5px;">R</div> <div style="border: 1px solid black; padding: 2px; margin-right: 5px;">O</div> <div style="border: 1px solid black; padding: 2px; margin-right: 5px;">S</div> <div style="border: 1px solid black; padding: 2px; margin-right: 5px;">K</div> <div style="border: 1px solid black; padding: 2px; margin-right: 5px;">R</div> <div style="border: 1px solid black; padding: 2px; margin-right: 5px;">O</div> <div style="border: 1px solid black; padding: 2px; margin-right: 5px;">S</div> <div style="border: 1px solid black; padding: 2px; margin-right: 5px;">K</div> <div style="border: 1px solid black; padding: 2px; margin-right: 5px;">R</div> <div style="border: 1px solid black; padding: 2px; margin-right: 5px;">O</div> <div style="border: 1px solid black; padding: 2px; margin-right: 5px;">S</div> <div style="border: 1px solid black; padding: 2px; margin-right: 5px;">K</div> <div style="border: 1px solid black; padding: 2px; margin-right: 5px;">R</div> <div style="border: 1px solid black; padding: 2px; margin-right: 5px;">O</div> <div style="border: 1px solid black; padding: 2px; margin-right: 5px;">S</div> <div style="border: 1px solid black; padding: 2px; margin-right: 5px;">K</div> <div style="border: 1px solid black; padding: 2px; margin-right: 5px;">R</div> <div style="border: 1px solid black; padding: 2px; margin-right: 5px;">O</div> <div style="border: 1px solid black; padding: 2px; margin-right: 5px;">S</div> <div style="border: 1px solid black; padding: 2px; margin-right: 5px;">K</div> <div style="border: 1px solid black; padding: 2px; margin-right: 5px;">R</div> <div style="border: 1px solid black; padding: 2px; margin-right: 5px;">O</div> <div style="border: 1px solid black; padding: 2px; margin-right: 5px;">S</div> <div style="border: 1px solid black; padding: 2px; margin-right: 5px;">K</div> <div style="border: 1px solid black; padding: 2px; margin-right: 5px;">R</div> <div style="border: 1px solid black; padding: 2px; margin-right: 5px;">O</div> <div style="border: 1px solid black; padding: 2px; margin-right: 5px;">S</div> <div style="border: 1px solid black; padding: 2px; margin-right: 5px;">K</div> <div style="border: 1px solid black; padding: 2px; margin-right: 5px;">R</div> <div style="border: 1px solid black; padding: 2px; margin-right: 5px;">O</div> <div style="border: 1px solid black; padding: 2px; margin-right: 5px;">S</div> <div style="border: 1px solid black; padding: 2px; margin-right: 5px;">K</div> <div style="border: 1px solid black; padding: 2px; margin-right: 5px;">R</div> <div style="border: 1px solid black; padding: 2px; margin-right: 5px;">O</div> <div style="border: 1px solid black; padding: 2px; margin-right: 5px;">S</div> <div style="border: 1px solid black; padding: 2px; margin-right: 5px;">K</div> <div style="border: 1px solid black; padding: 2px; margin-right: 5px;">R</div> <div style="border: 1px solid black; padding: 2px; margin-right: 5px;">O</div> <div style="border: 1px solid black; padding: 2px; margin-right: 5px;">S</div> <div style="border: 1px solid black; padding: 2px; margin-right: 5px;">K</div> <div style="border: 1px solid black; padding: 2px; margin-right: 5px;">R</div> <div style="border: 1px solid black; padding: 2px; margin-right: 5px;">O</div> <div style="border: 1px solid black; padding: 2px; margin-right: 5px;">S</div> <div style="border: 1px solid black; padding: 2px; margin-right: 5px;">K</div> <div style="border: 1px solid black; padding: 2px; margin-right: 5px;">R</div> <div style="border: 1px solid black; padding: 2px; margin-right: 5px;">O</div> <div style="border: 1px solid black; padding: 2px; margin-right: 5px;">S</div> <div style="border: 1px solid black; padding: 2px; margin-right: 5px;">K</div> <div style="border: 1px solid black; padding: 2px; margin-right: 5px;">R</div> <div style="border: 1px solid black; padding: 2px; margin-right: 5px;">O</div> <div style="border: 1px solid black; padding: 2px; margin-right: 5px;">S</div> <div style="border: 1px solid black; padding: 2px; margin-right: 5px;">K</div> <div style="border: 1px solid black; padding: 2px; margin-right: 5px;">R</div> <div style="border: 1px solid black; padding: 2px; margin-right: 5px;">O</div> <div style="border: 1px solid black; padding: 2px; margin-right: 5px;">S</div> <div style="border: 1px solid black; padding: 2px; margin-right: 5px;">K</div> <div style="border: 1px solid black; padding: 2px; margin-right: 5px;">R</div> <div style="border: 1px solid black; padding: 2px; margin-right: 5px;">O</div> <div style="border: 1px solid black; padding: 2px; margin-right: 5px;">S</div> <div style="border: 1px solid black; padding: 2px; margin-right: 5px;">K</div> <div style="border: 1px solid black; padding: 2px; margin-right: 5px;">R</div> <div style="border: 1px solid black; padding: 2px; margin-right: 5px;">O</div> <div style="border: 1px solid black; padding: 2px; margin-right: 5px;">S</div> <div style="border: 1px solid black; padding: 2px; margin-right: 5px;">K</div> <div style="border: 1px solid black; padding: 2px; margin-right: 5px;">R</div> <div style="border: 1px solid black; padding: 2px; margin-right: 5px;">O</div> <div style="border: 1px solid black; padding: 2px; margin-right: 5px;">S</div> <div style="border: 1px solid black; padding: 2px; margin-right: 5px;">K</div> <div style="border: 1px solid black; padding: 2px; margin-right: 5px;">R</div> <div style="border: 1px solid black; padding: 2px; margin-right: 5px;">O</div> <div style="border: 1px solid black; padding: 2px; margin-right: 5px;">S</div> <div style="border: 1px solid black; padding: 2px; margin-right: 5px;">K</div> <div style="border: 1px solid black; padding: 2px; margin-right: 5px;">R</div> <div style="border: 1px solid black; padding: 2px; margin-right: 5px;">O</div> <div style="border: 1px solid black; padding: 2px; margin-right: 5px;">S</div> <div style="border: 1px solid black; padding: 2px; margin-right: 5px;">K</div> <div style="border: 1px solid black; padding: 2px; margin-right: 5px;">R</div> <div style="border: 1px solid black; padding: 2px; margin-right: 5px;">O</div> <div style="border: 1px solid black; padding: 2px; margin-right: 5px;">S</div> <div style="border: 1px solid black; padding: 2px; margin-right: 5px;">K</div> <div style="border: 1px solid black; padding: 2px; margin-right: 5px;">R</div> <div style="border: 1px solid black; padding: 2px; margin-right: 5px;">O</div> <div style="border: 1px solid black; padding: 2px; margin-right: 5px;">S</div> <div style="border: 1px solid black; padding: 2px; margin-right: 5px;">K</div> <div style="border: 1px solid black; padding: 2px; margin-right: 5px;">R</div> <div style="border: 1px solid black; padding: 2px; margin-right: 5px;">O</div> <div style="border: 1px solid black; padding: 2px; margin-right: 5px;">S</div> <div style="border: 1px solid black; padding: 2px; margin-right: 5px;">K</div> <div style="border: 1px solid black; padding: 2px; margin-right: 5px;">R</div> <div style="border: 1px solid black; padding: 2px; margin-right: 5px;">O</div> <div style="border: 1px solid black; padding: 2px; margin-right: 5px;">S</div> <div style="border: 1px solid black; padding: 2px; margin-right: 5px;">K</div> <div style="border: 1px solid black; padding: 2px; margin-right: 5px;">R</div> <div style="border: 1px solid black; padding: 2px; margin-right: 5px;">O</div> <div style="border: 1px solid black; padding: 2px; margin-right: 5px;">S</div> <div style="border: 1px solid black; padding: 2px; margin-right: 5px;">K</div> <div style="border: 1px solid black; padding: 2px; margin-right: 5px;">R</div> <div style="border: 1px solid black; padding: 2px; margin-right: 5px;">O</div> <div style="border: 1px solid black; padding: 2px; margin-right: 5px;">S</div> <div style="border: 1px solid black; padding: 2px; margin-right: 5px;">K</div> <div style="border: 1px solid black; padding: 2px; margin-right: 5px;">R</div> <div style="border: 1px solid black; padding: 2px; margin-right: 5px;">O</div> <div style="border: 1px solid black; padding: 2px; margin-right: 5px;">S</div> <div style="border: 1px solid black; padding: 2px; margin-right: 5px;">K</div> <div style="border: 1px solid black; padding: 2px; margin-right: 5px;">R</div> <div style="border: 1px solid black; padding: 2px; margin-right: 5px;">O</div> <div style="border: 1px solid black; padding: 2px; margin-right: 5px;">S</div> <div style="border: 1px solid black; padding: 2px; margin-right: 5px;">K</div> <div style="border: 1px solid black; padding: 2px; margin-right: 5px;">R</div> <div style="border: 1px solid black; padding: 2px; margin-right: 5px;">O</div> <div style="border: 1px solid black; padding: 2px; margin-right: 5px;">S</div> <div style="border: 1px solid black; padding: 2px; margin-right: 5px;">K</div> <div style="border: 1px solid black; padding: 2px; margin-right: 5px;">R</div> <div style="border: 1px solid black; padding: 2px; margin-right: 5px;">O</div> <div style="border: 1px solid black; padding: 2px; margin-right: 5px;">S</div> <div style="border: 1px solid black; padding: 2px; margin-right: 5px;">K</div> <div style="border: 1px solid black; padding: 2px; margin-right: 5px;">R</div> <div style="border: 1px solid black; padding: 2px; margin-right: 5px;">O</div> <div style="border: 1px solid black; padding: 2px; margin-right: 5px;">S</div> <div style="border: 1px solid black; padding: 2px; margin-right: 5px;">K</div> <div style="border: 1px solid black; padding: 2px; margin-right: 5px;">R</div> <div style="border: 1px solid black; padding: 2px; margin-right: 5px;">O</div> <div style="border: 1px solid black; padding: 2px; margin-right: 5px;">S</div> <div style="border: 1px solid black; padding: 2px; margin-right: 5px;">K</div> <div style="border: 1px solid black; padding: 2px; margin-right: 5px;">R</div> <div style="border: 1px solid black; padding: 2px; margin-right: 5px;">O</div> <div style="border: 1px solid black; padding: 2px; margin-right: 5px;">S</div> <div style="border: 1px solid black; padding: 2px; margin-right: 5px;">K</div> <div style="border: 1px solid black; padding: 2px; margin-right: 5px;">R</div> <div style="border: 1px solid black; padding: 2px; margin-right: 5px;">O</div> <div style="border: 1px solid black; padding: 2px; margin-right: 5px;">S</div> <div style="border: 1px solid black; padding: 2px; margin-right: 5px;">K</div> <div style="border: 1px solid black; padding: 2px; margin-right: 5px;">R</div> <div style="border: 1px solid black; padding: 2px; margin-right: 5px;">O</div> <div style="border: 1px solid black; padding: 2px; margin-right: 5px;">S</div> <div style="border: 1px solid black; padding: 2px; margin-right: 5px;">K</div> <div style="border: 1px solid black; padding: 2px; margin-right: 5px;">R</div> <div style="border: 1px solid black; padding: 2px; margin-right: 5px;">O</div> <div style="border: 1px solid black; padding: 2px; margin-right: 5px;">S</div> <div style="border: 1px solid black; padding: 2px; margin-right: 5px;">K</div> <div style="border: 1px solid black; padding: 2px; margin-right: 5px;">R</div> <div style="border: 1px solid black; padding: 2px; margin-right: 5px;">O</div> <div style="border: 1px solid black; padding: 2px; margin-right: 5px;">S</div> <div style="border: 1px solid black; padding: 2px; margin-right: 5px;">K</div> <div style="border: 1px solid black; padding: 2px; margin-right: 5px;">R</div> <div style="border: 1px solid black; padding: 2px; margin-right: 5px;">O</div> <div style="border: 1px solid black; padding: 2px; margin-right: 5px;">S</div> <div style="border: 1px solid black; padding: 2px; margin-right: 5px;">K</div> <div style="border: 1px solid black; padding: 2px; margin-right: 5px;">R</div> <div style="border: 1px solid black; padding: 2px; margin-right: 5px;">O</div> <div style="border: 1px solid black; padding: 2px; margin-right: 5px;">S</div> <div style="border: 1px solid black; padding: 2px; margin-right: 5px;">K</div> <div style="border: 1px solid black; padding: 2px; margin-right: 5px;">R</div> <div style="border: 1px solid black; padding: 2px; margin-right: 5px;">O</div> <div style="border: 1px solid black; padding: 2px; margin-right: 5px;">S</div> <div style="border: 1px solid black; padding: 2px; margin-right: 5px;">K</div> <div style="border: 1px solid black; padding: 2px; margin-right: 5px;">R</div> <div style="border: 1px solid black; padding: 2px; margin-right: 5px;">O</div> <div style="border: 1px solid black; padding: 2px; margin-right: 5px;">S</div> <div style="border: 1px solid black; padding: 2px; margin-right: 5px;">K</div> <div style="border: 1px solid black; padding: 2px; margin-right: 5px;">R</div> <div style="border: 1px solid black; padding: 2px; margin-right: 5px;">O</div> <div style="border: 1px solid black; padding: 2px; margin-right: 5px;">S</div> <div style="border: 1px solid black; padding: 2px; margin-right: 5px;">K</div> <div style="border: 1px solid black; padding: 2px; margin-right: 5px;">R</div> <div style="border: 1px solid black; padding: 2px; margin-right: 5px;">O</div> <div style="border: 1px solid black; padding: 2px; margin-right: 5px;">S</div> <div style="border: 1px solid black; padding: 2px; margin-right: 5px;">K</div> <div style="border: 1px solid black; padding: 2px; margin-right: 5px;">R</div> <div style="border: 1px solid black; padding: 2px; margin-right: 5px;">O</div> <div style="border: 1px solid black; padding: 2px; margin-right: 5px;">S</div> <div style="border: 1px solid black; padding: 2px; margin-right: 5px;">K</div> <div style="border: 1px solid black; padding: 2px; margin-right: 5px;">R</div> <div style="border: 1px solid black; padding: 2px; margin-right: 5px;">O</div> <div style="border: 1px solid black; padding: 2px; margin-right: 5px;">S</div> <div style="border: 1px solid black; padding: 2px; margin-right: 5px;">K</div> <div style="border: 1px solid black; padding: 2px; margin-right: 5px;">R</div> <div style="border: 1px solid black; padding: 2px; margin-right: 5px;">O</div> <div style="border: 1px solid black; padding: 2px; margin-right: 5px;">S</div> <div style="border: 1px solid black; padding: 2px; margin-right: 5px;">K</div> <div style="border: 1px solid black; padding: 2px; margin-right: 5px;">R</div> <div style="border: 1px solid black; padding: 2px; margin-right: 5px;">O</div> <div style="border: 1px solid black; padding: 2px; margin-right: 5px;">S</div> <div style="border: 1px solid black; padding: 2px; margin-right: 5px;">K</div> <div style="border: 1px solid black; padding: 2px; margin-right: 5px;">R</div> <div style="border: 1px solid black; padding: 2px; margin-right: 5px;">O</div> <div style="border: 1px solid black; padding: 2px; margin-right: 5px;">S</div> <div style="border: 1px solid black; padding: 2px; margin-right: 5px;">K</div> <div style="border: 1px solid black; padding: 2px; margin-right: 5px;">R</div> <div style="border: 1px solid black; padding: 2px; margin-right: 5px;">O</div> <div style="border: 1px solid black; padding: 2px; margin-right: 5px;">S</div> <div style="border: 1px solid black; padding: 2px; margin-right: 5px;">K</div> <div style="border: 1px solid black; padding: 2px; margin-right: 5px;">R</div> <div style="border: 1px solid black; padding: 2px; margin-right: 5px;">O</div> <div style="border: 1px solid black; padding: 2px; margin-right: 5px;">S</div> <div style="border: 1px solid black; padding: 2px; margin-right: 5px;">K</div> <div style="border: 1px solid black; padding: 2px; margin-right: 5px;">R</div> <div style="border: 1px solid black; padding: 2px; margin-right: 5px;">O</div> <div style="border: 1px solid black; padding: 2px; margin-right: 5px;">S</div> <div style="border: 1px solid black; padding: 2px; margin-right: 5px;">K</div> <div style="border: 1px solid black; padding: 2px; margin-right: 5px;">R</div> <div style="border: 1px solid black; padding: 2px; margin-right: 5px;">O</div> <div style="border: 1px solid black; padding: 2px; margin-right: 5px;">S</div> <div style="border: 1px solid black; padding: 2px; margin-right: 5px;">K</div> <div style="border: 1px solid black; padding: 2px; margin-right: 5px;">R</div> <div style="border: 1px solid black; padding: 2px; margin-right: 5px;">O</div> <div style="border: 1px solid black; padding: 2px; margin-right: 5px;">S</div> <div style="border: 1px solid black; padding: 2px; margin-right: 5px;">K</div> <div style="border: 1px solid black; padding: 2px; margin-right: 5px;">R</div> <div style="border: 1px solid black; padding: 2px; margin-right: 5px;">O</div> <div style="border: 1px solid black; padding: 2px; margin-right: 5px;">S</div> <div style="border: 1px solid black; padding: 2px; margin-right: 5px;">K</div> <div style="border: 1px solid black; padding: 2px; margin-right: 5px;">R</div> <div style="border: 1px solid black; padding: 2px; margin-right: 5px;">O</div> <div style="border: 1px solid black; padding: 2px; margin-right: 5px;">S</div> <div style="border: 1px solid black; padding: 2px; margin-right: 5px;">K</div> <div style="border: 1px solid black; padding: 2px; margin-right: 5px;">R</div> <div style="border: 1px solid black; padding: 2px; margin-right: 5px;">O</div> <div style="border: 1px solid black; padding: 2px; margin-right: 5px;">S</div> <div style="border: 1px solid black; padding: 2px; margin-right: 5px;">K</div> </div>					

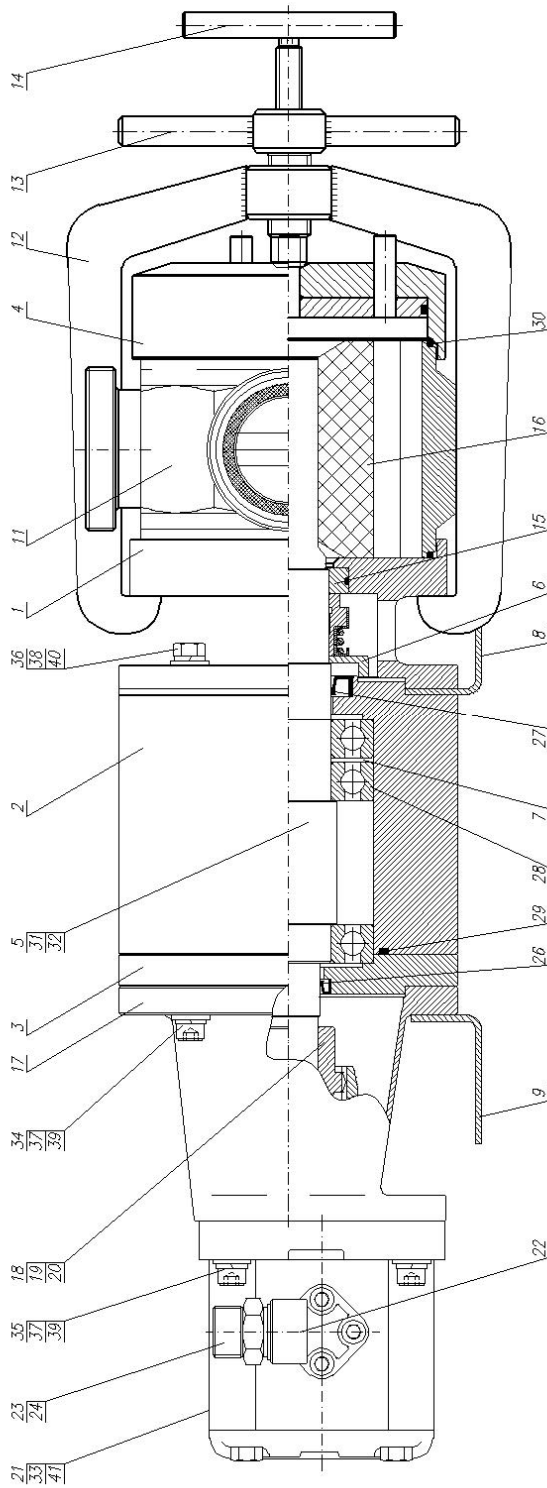

Pompa mleka PM30

Nr rysunku:

41	Podkładka sprężysta 12,2	PN-77/M-82008	1	Fe/Zn	
40	Podkładka sprężysta 8,2	PN-77/M-82008	4	A2	
39	Podkładka sprężysta 8,2	PN-77/M-82008	8	Fe/Zn	
38	Podkładka 8,5	PN-78/M-82005	4	A2	
37	Podkładka 8,5	PN-78/M-82005	8	Fe/Zn	
36	Śruba z łbem sześciokątnym M8x25	PN-85/M-82105	4	A2-70	
35	Śruba z łbem walcowym z gniazdem sześciokątnym M8x30-8,8	PN-87/M-82302	4	Fe/Zn	
34	Śruba z łbem walcowym z gniazdem sześciokątnym M8x45-8,8	PN-87/M-82302	4	Fe/Zn	
33	Nakrętka niska M12x1,25-8	PN-86/M-82153	1	Fe/Zn	
32	Wpust czułekowy	PN-73/M-85008	1		0656-200-0089
31	Wpust pryzmatyczny	PN-70/M-85005	1		0656-200-0090
30	O-ring 129,77x3,53	PN-68/H-74378	2	VMQ lub MVQ	1373-123-0011
29	O-ring 88,5x3,53	PN-68/H-74378	1		1373-212-0043
28	Łożysko kulkowe 6208-2RS	PN-85/M-86100	3		0631-113-0039
27	Uszczelniacz 60x40x10	PN-72/M-86964	1		1373-119-0076
26	Uszczelniacz 40x30x7	PN-72/M-86964	1		1373-120-0018
25					
24	Korpus przyłączki prostej M24x1,5/G1/2	PN-65/M-73125	2	Nr kat. wg. WIZAMOR 20-04.76.5	0616-129-0091
23	Uszczelka metalowa-gumowa 26,7x21,65x1,25	art. handlowy	2	1036050513	1373-123-0016
22	Kółnik z oringiem 90° cynkowany	WDS 2 12	2		0616-131-0029
21	Silnik hydrauliczny		1		0843-162-0051
20	Tuleja BoWex	M-28	1		0824-311-0016
19	Piasta BoWex	M-28	1		0859-540-0003
18	Piasta BoWex	M-28	1		0859-540-0055
17	Łącznik	PL 160/4/3	1		0642-300-0066
16	Wirnik gumowy z wkładką metalową	JO-30	1		0843-162-0046
15	Uszczelnienie		1		0843-160-0008
14	Śruba docisku tarczy	CW00.043.00.0	1		
13	Śruba pokrywy mycia	CW00.042.00.0	1		
12	Docisk	CW00.041.00.2	1		całkowita długość tapy 253 mm
11	Korpus	PM30.010.00.0	1		
10					
9	Stopa tylna	PM24.000.09.0	1		
8	Stopa przednia	PM24.000.08.0	1		
7	Dystans	PM24.000.07.0	1		
6	Pierscień	PM24.000.06.0	1		
5	Wał	PM24.000.05.0	1		
4	Pokrywa kompletna	CW00.030.00.0	1		z funkcją mycia
3	Pokrywa piasty	PM24.000.03.0	1		
2	Piasta	PM24.000.02.0	1		
1	Łącznik	PM24.000.01.0	1		
Nr kol.	Nazwa	Nr rys. lub normy	Ilość szt.	Material	Uwagi

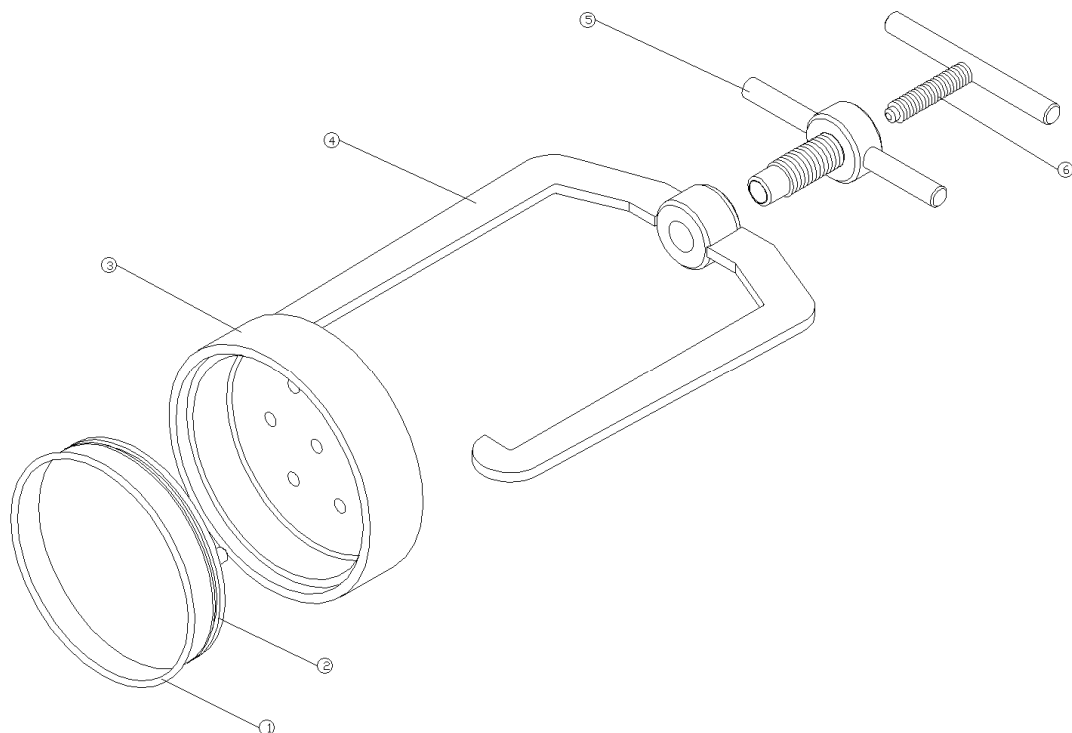

UWAGA!
Zamawiając korpus mycia podać wydajności pompy 24 czy 30 tyś/h (inny rozmiar uchwyty dociskowego)

Pozycja	Nazwa		Uwagi
1	O- ring pokrywy mycia 125x3		
2	Pierścień dociskowy		
3	Dekiel mycia		
4	Uchwyt dociskowy		Różne wersje
5	Śruba dociskowa uchwyty		
6	Śruba pierścienia dociskowego		



Pompa mleka korpus mycia

Nr rysunku:



Pozycja	Nazwa		Uwagi
1	Drukarka APUL		WSK KROSNO
2	Papier termiczny	Szer. 58 mm	



**Drukarka termiczna
CUSTOM**

Nr rysunku:



Pozycja	Nazwa		Uwagi
1	Drukarka Myszka 12M		
2	Papier termiczny	Szer. 58 mm	



**Drukarka termiczna
MEFA**

Nr rysunku:

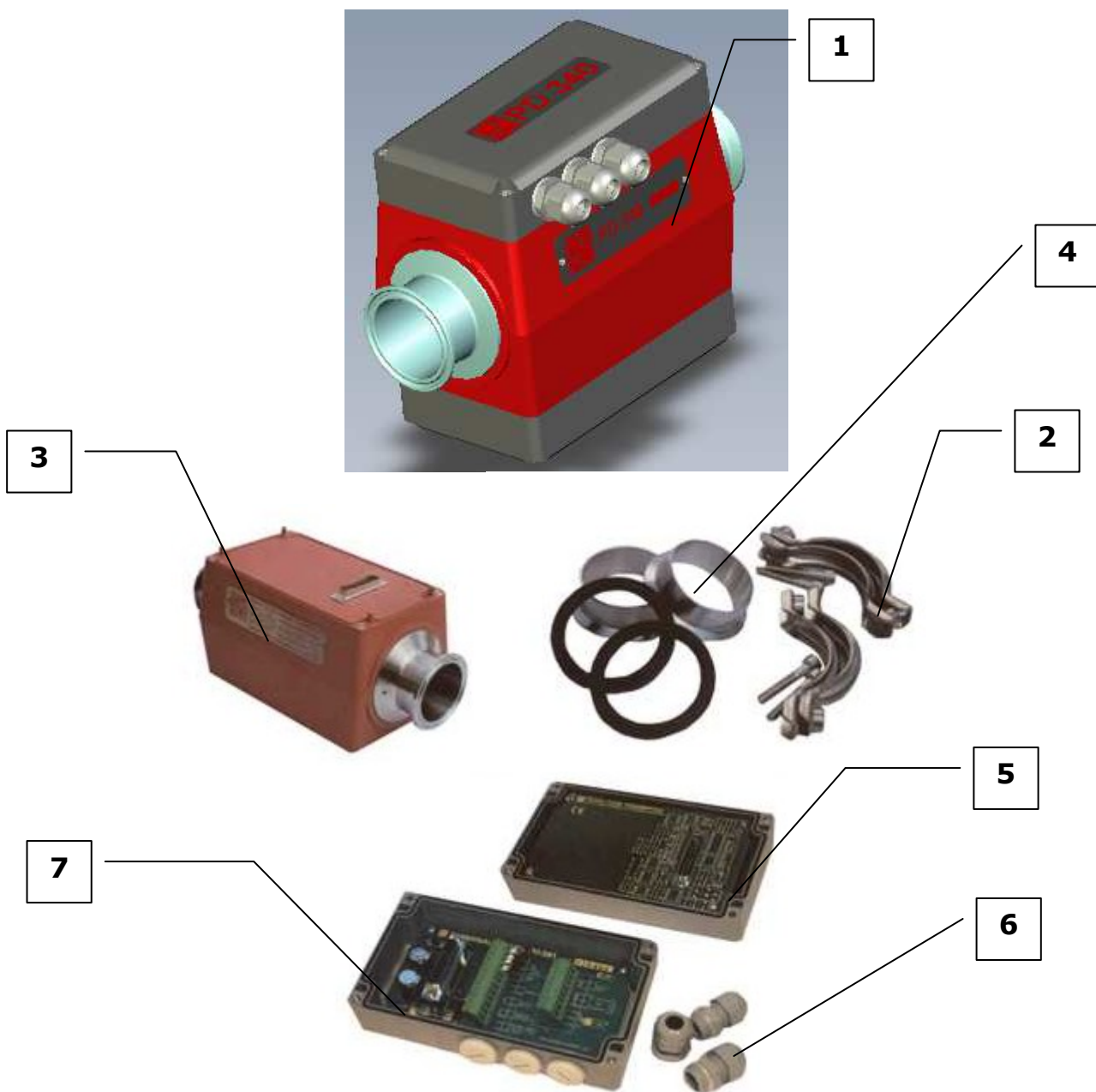

Pozycja	Nazwa		Uwagi
1	Przepływomierz PD340 C51 kpl.	611500	Proces-Data
2	Klamra lekka DN50	Nr kat. 287	ARMAPOL
3	Komora pomiarowa C51	600077	Proces-Data
4	Uszczelka DN50 DIN	Nr kat 288	ARMAPOL
5	Moduł elektroniczny extended version, dla PD 340 C 51-1-000	613500	Proces-Data
6	Dławik Pg11		
7	Płyta przyłączeniowa z obudową	600074	Proces-Data



**Przepływomierz PD-340
C51**

Nr rysunku:

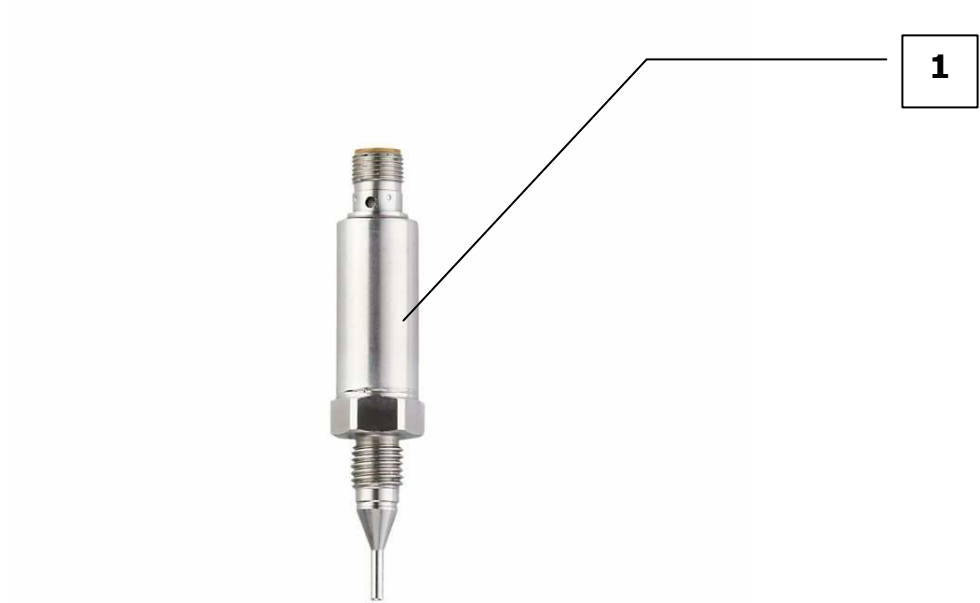

Pozycja	Nazwa		Uwagi
1	Czujnik temperatury PT100	TA1107	
2	Kabel przyłączeniowy M12 4 styki		



**Czujnik temperatury
TA1107**

Nr rysunku:

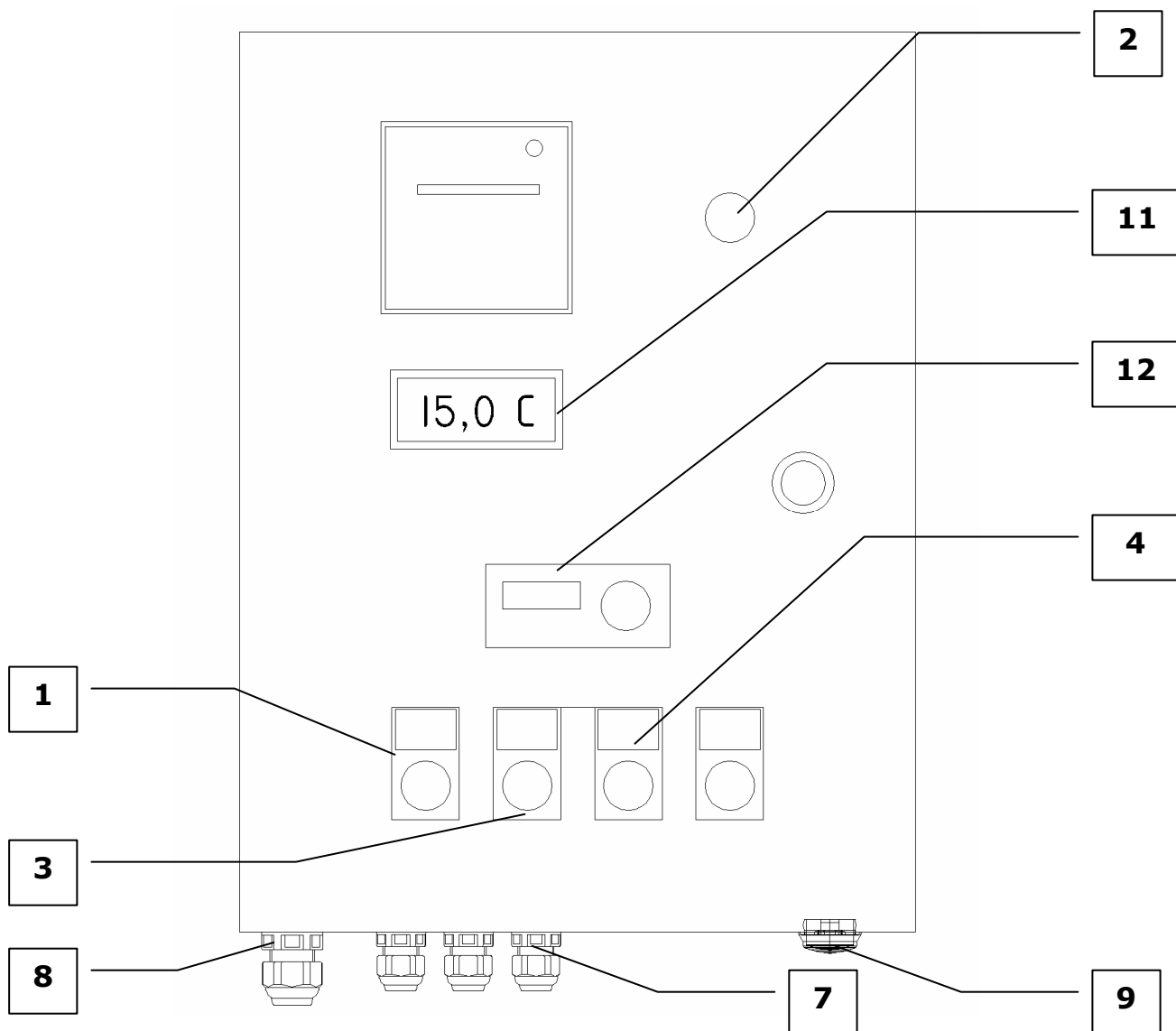

Pozycja	Nazwa		Uwagi
1	Przełącznik 3-pozycyjny	XB4-BK133B5	Telemecanique
2	Przycisk wandaloodporny		
3	Przełącznik 3-pozycyjny	XB4-DB33	Telemecanique
4	Przełącznik 2 -pozycyjny	XB4-DB21	Telemecanique
5	Element zestykowy	ZBE-101	Telemecanique
6	Element zestykowy	ZBE-102	Telemecanique
7	Dławnica Pg9 (M16x15)		
8	Dławnica Pg11 (M20x1,5)		
9	Port ETH		
10	Zamek na klucz (lub KNOBLOCK)		
11	Termostat APAR		
12	Sterownik ogrzewania Ebersaecher		

W zależności od wersji wykonania skrzynka sterownicza może różnić się od siebie wyposażeniem oraz wielkością.



Skrzynka sterownicza
- panel przedni

Nr rysunku:

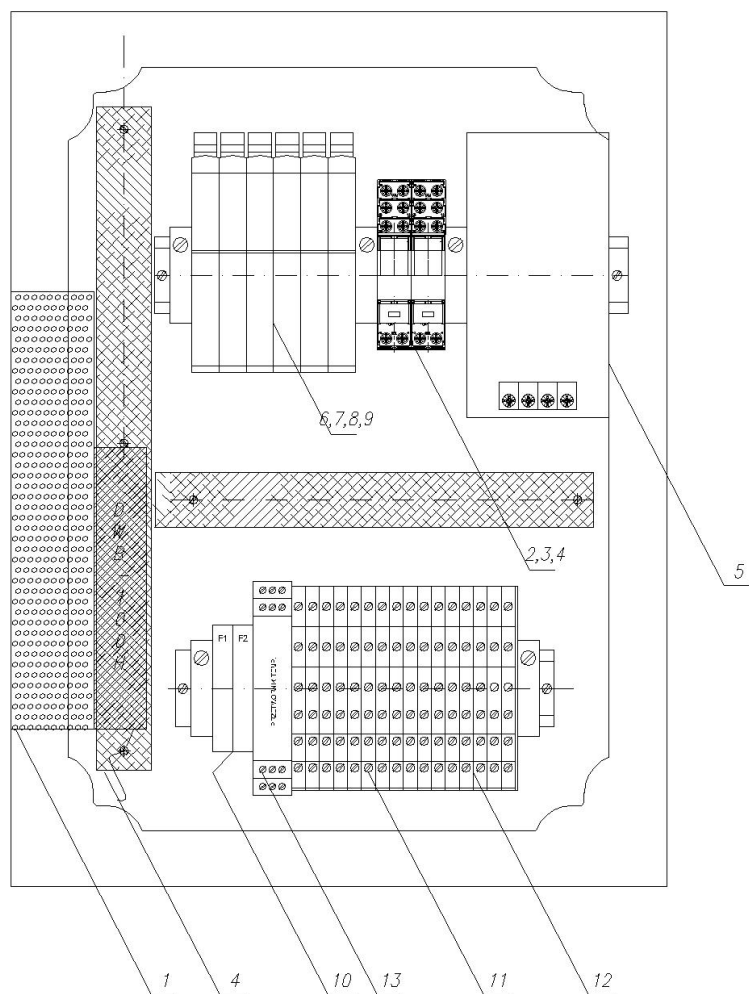

W zależności od wersji wykonania skrzynka sterownicza może różnić się od siebie wyposażeniem.

Pozycja	Nazwa		Uwagi
1	Zasilacz SD-100B-24		
2	Oprawa przekaźnikowa		
3	Przełącznik RM94/RM84		
4	Obejma		
5	POWER Bufor		
6	Moduł X20 9300		PROCES-DATA
7	Moduł X20 8281		
8	Moduł X20 9324		
9	Moduł X20 1436		
10	Oprawa bezpiecznikowa		
11	Listwa szynowa 3 piętrowa	ZG-G/31	
12	Listwa szynowa 3 piętrowa	ZG-G/31/E0	
13	Moduł przełącznika RS232		
14	Radiolinia 2 kanałowa		



**Skrzynka sterownicza
- wnętrze**

Nr rysunku:

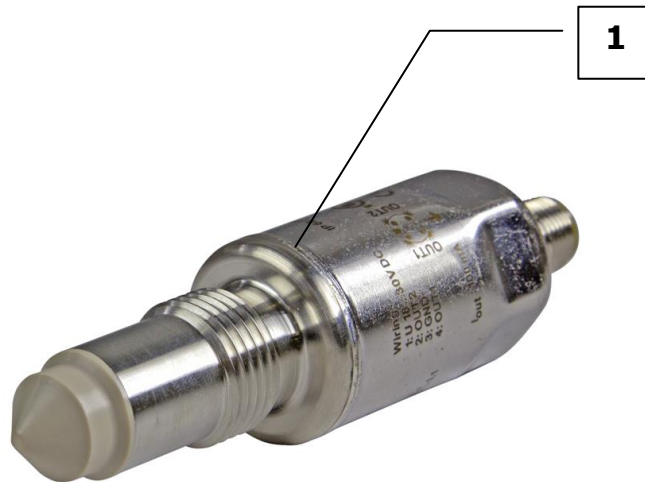

Pozycja	Nazwa		Uwagi
1	Sygnalizator cieczy		
2	Przewód połączeniowy M12 4 pin		
3	Mufa G 1/2"		



Sygnalizator cieczy

Nr rysunku:

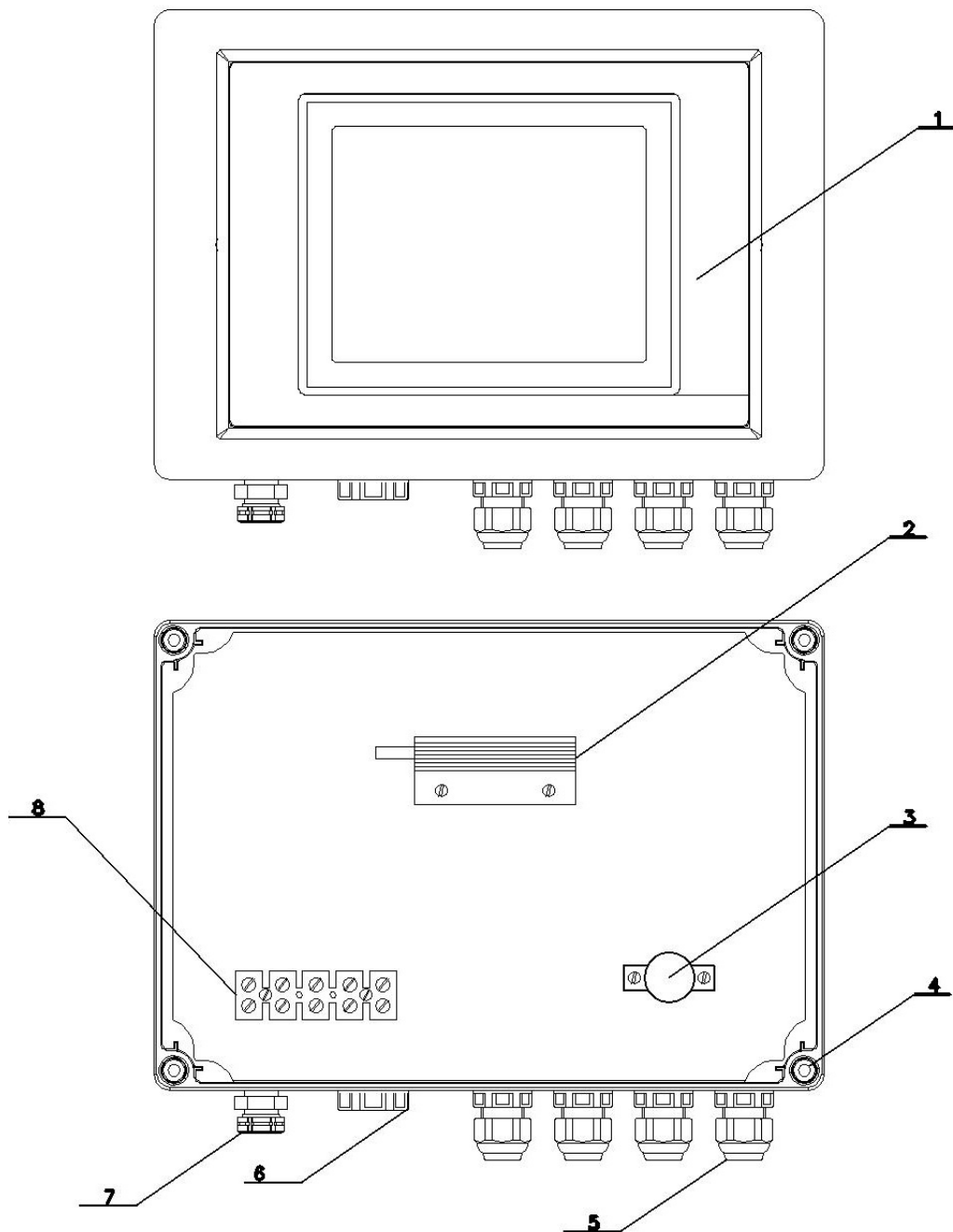

Pozycja	Nazwa		Uwagi
1	Panel dotykowy PP65 5,7"		
2	Element grzewczy PTC		
3	Termostat bimetaliczny		
4	Obudowa 180x250x100		
5	Dławnica M16x1,5		
6	Port USB		
7	Element wyrównujący ciśnienie		
8	Listwa przyłączeniowa		



**Komputer
KRO5**

Nr rysunku:



Pozycja	Nazwa		Uwagi
1	Radiolinia 2 - kanałowa	DWB100H	
2	Pilot	DWB100HT	



RADIOLINIA 2 KANAŁOWA

Nr rysunku:

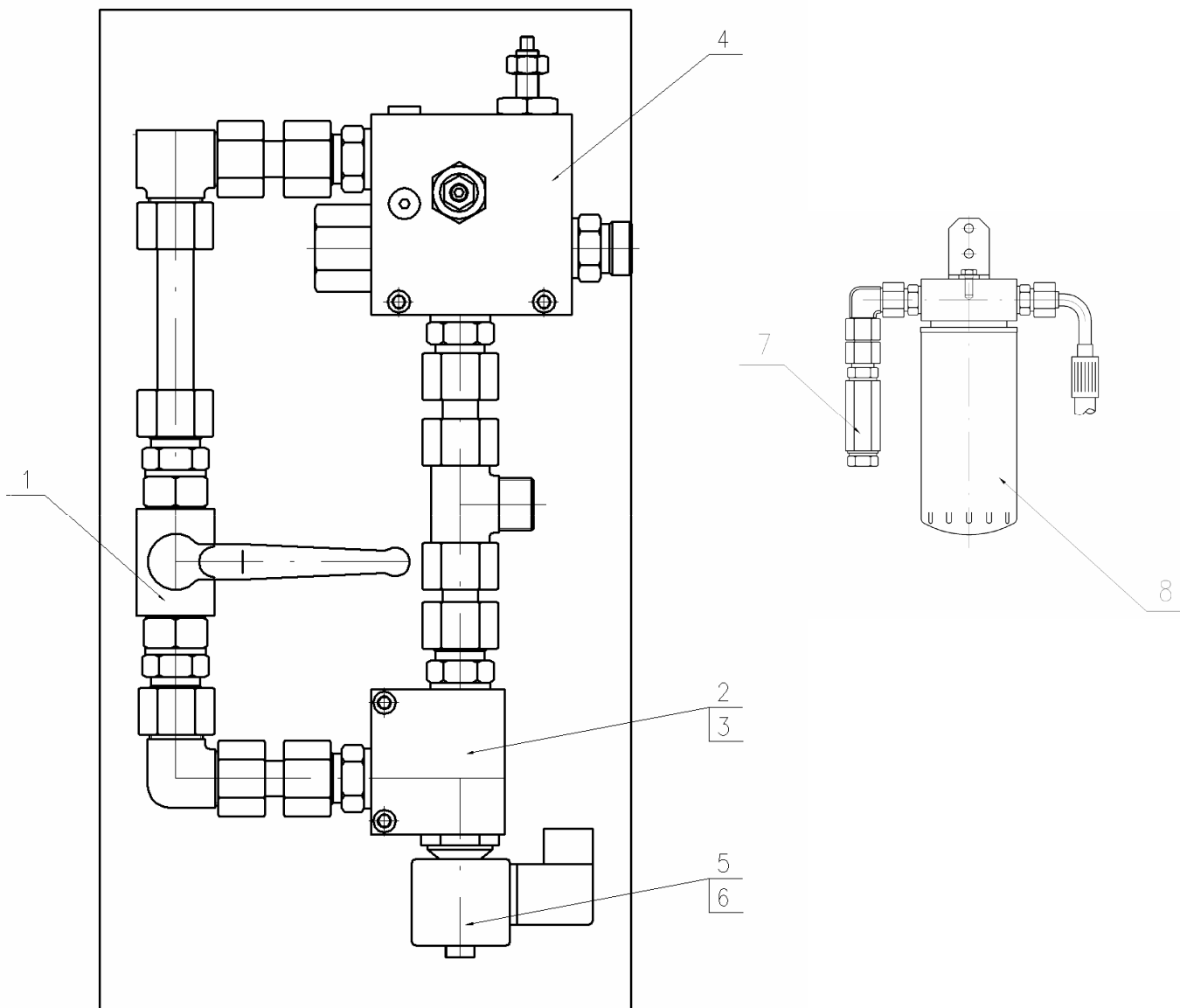

Przewody hydrauliczne \varnothing wewnętrzne 12, złącze M24x1,5 – Przy zamówieniu należy określić długość i rodzaj okucia (kolano lub proste). Przewód hydrauliczny od filtra do zbiornika \varnothing wewnętrzne. 16, złącze G3/4" – Podać długość i rodzaj okuć.

Pozycja	Nazwa		Uwagi
1	Dwukierunkowy zawór kulowy		
2	Obudowa zaworu	R901180260	
3	Zawór elektromagnetyczny	R901113677	
4	Regulator przepływu	R930004267	
5	Cewka elektrozaworu	R901083065	
6	Złącze elektr. elektrozaworu		HIRSCHMANN
7	Zawór zwrotny	S10A-A2.0	
8	Wkład filtra oleju	HP 12,3	FH Sędziszów



Układ hydrauliczny

Nr rysunku:

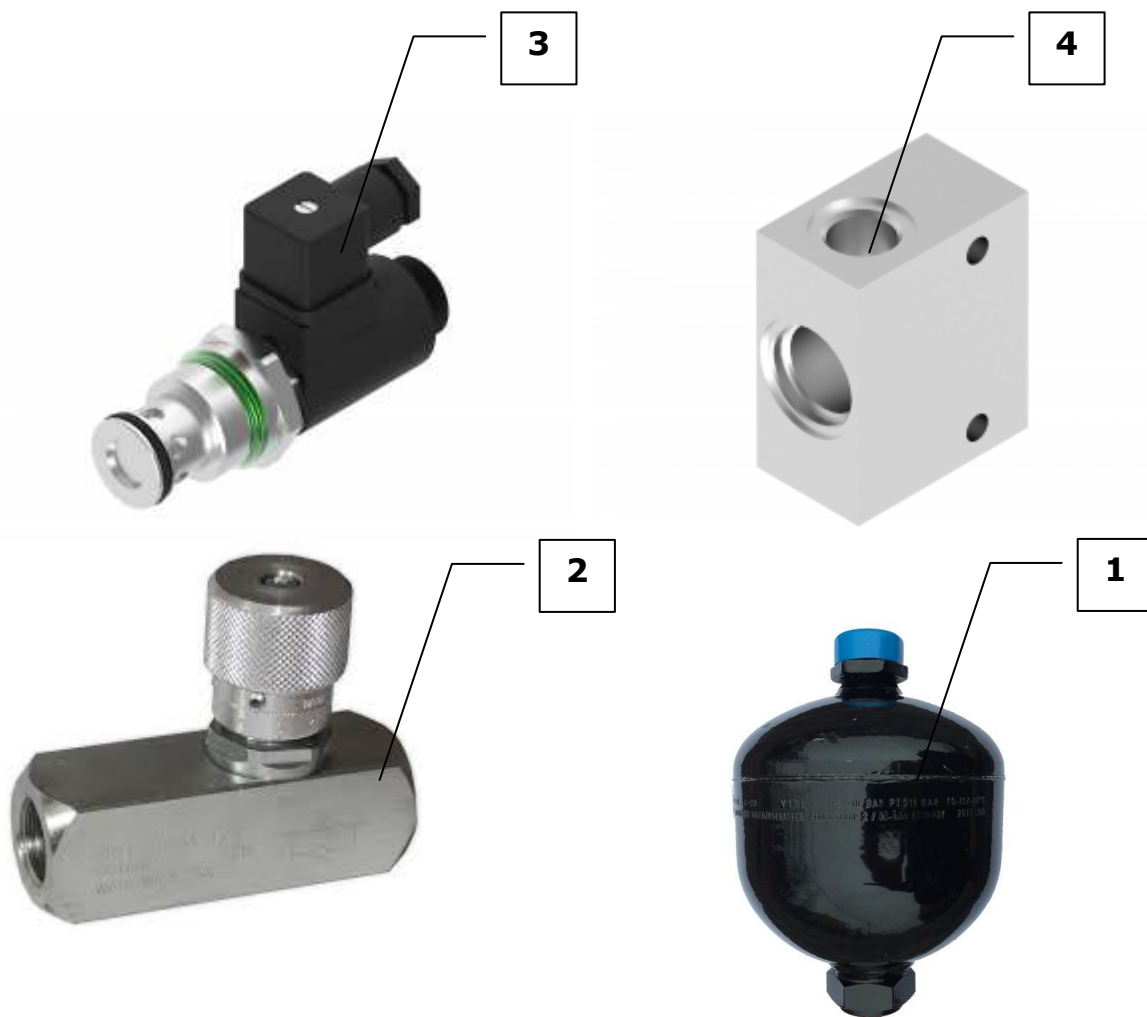

Przewody hydrauliczne \varnothing wewnętrzne 12, złącze M24x1,5 – Przy zamówieniu należy określić długość i rodzaj okucia (kolano lub proste).

Pozycja	Nazwa		Uwagi
1	Akumulator		
2	Zawór zwrotno-dławiący z pokrętkiem		
3	Rozdzielacz naboju	2URES	
4	Płyta przyłączeniowa	2UL06/1-G3	



**Układ hydrauliczny
- układ dławiący**

Nr rysunku:

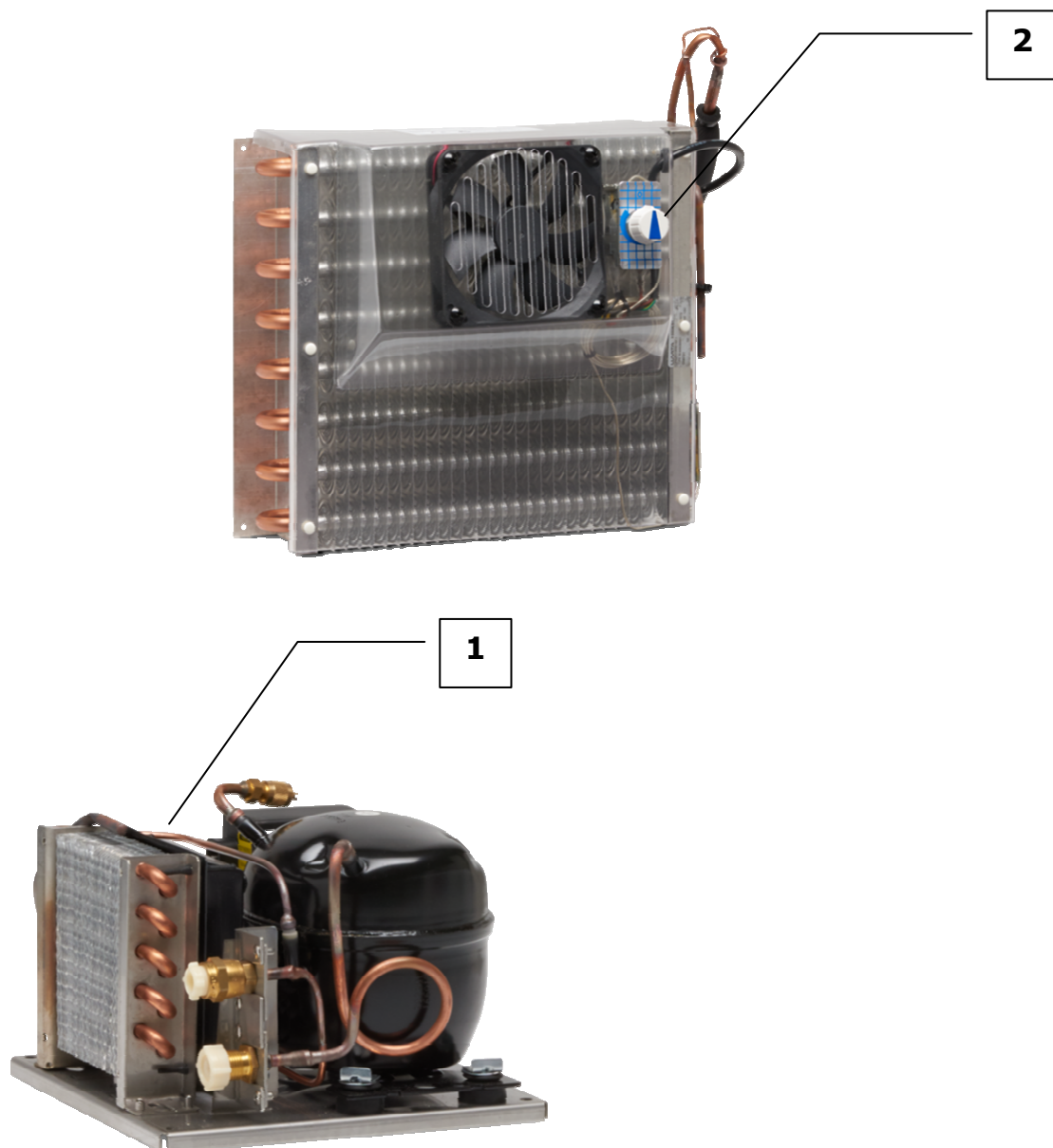

Pozycja	Nazwa		Uwagi
1	Agregat chłodniczy		
2	Parowacz z nawiewem i termostatem	VD-16	
3	Kanał wentylacyjny		

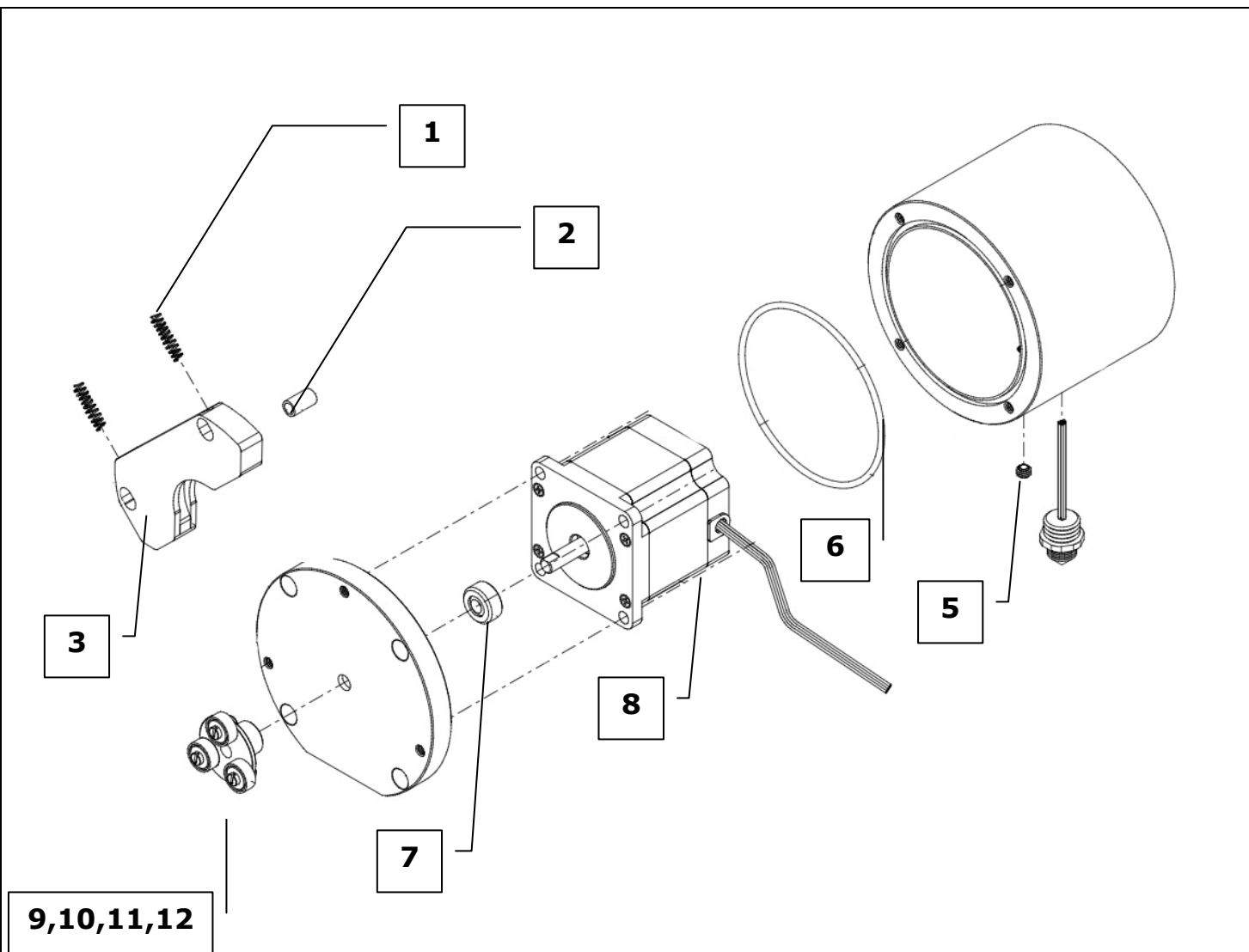

Pozycja	Nazwa		Uwagi
1	Sprężyna bieźni		
2	Tuleja		
3	Bieźnia		
5	Tłumik		
6	O-ring 75,78x2,62		
7	Simering 6x16x7		
8	Silnik krokowy		
9	Łożysko W624ZZ		
10	Wirnik		
11	Sworzeń łożyska		
12	Śruba M3x5		
13	Wężyk silikonowy		



Pobieracz próbek

Nr rysunku:

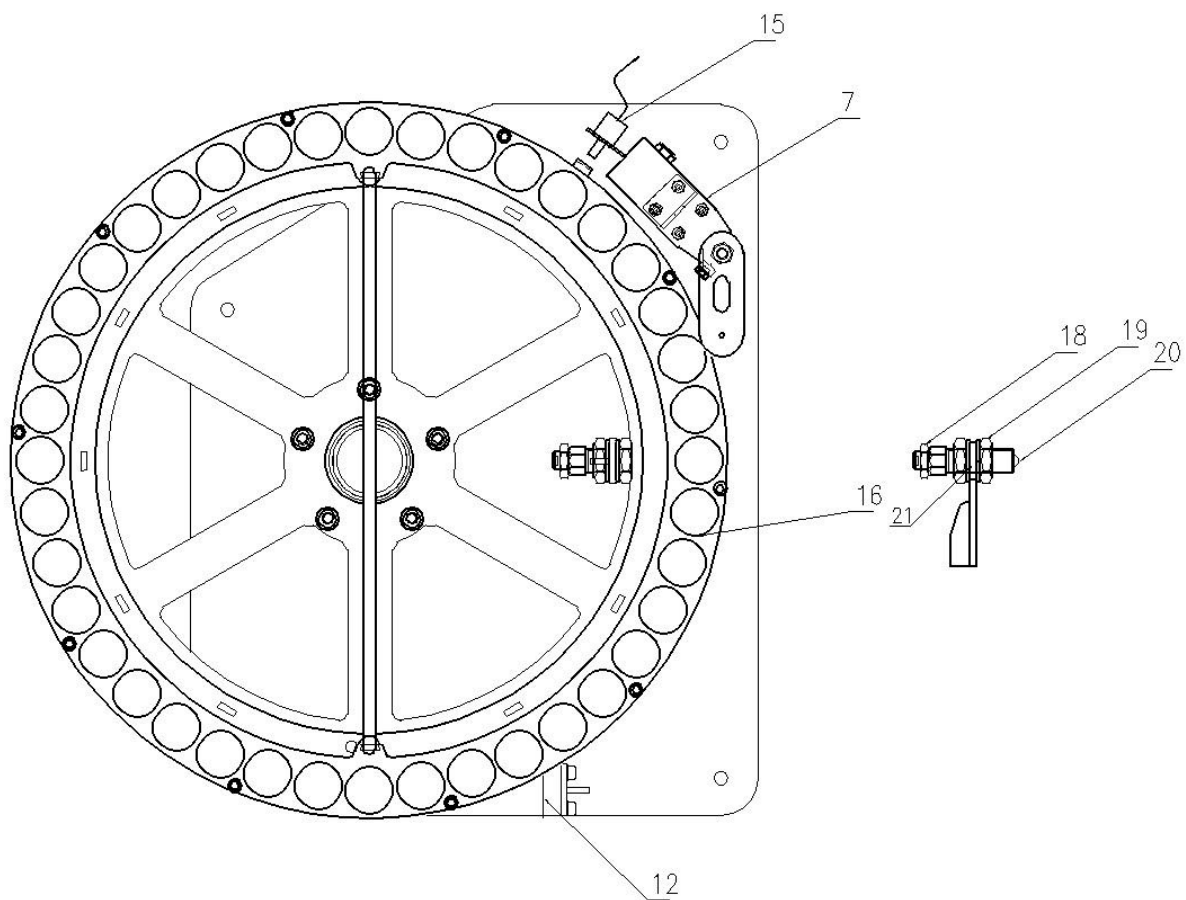
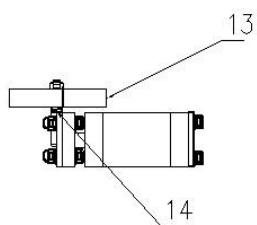
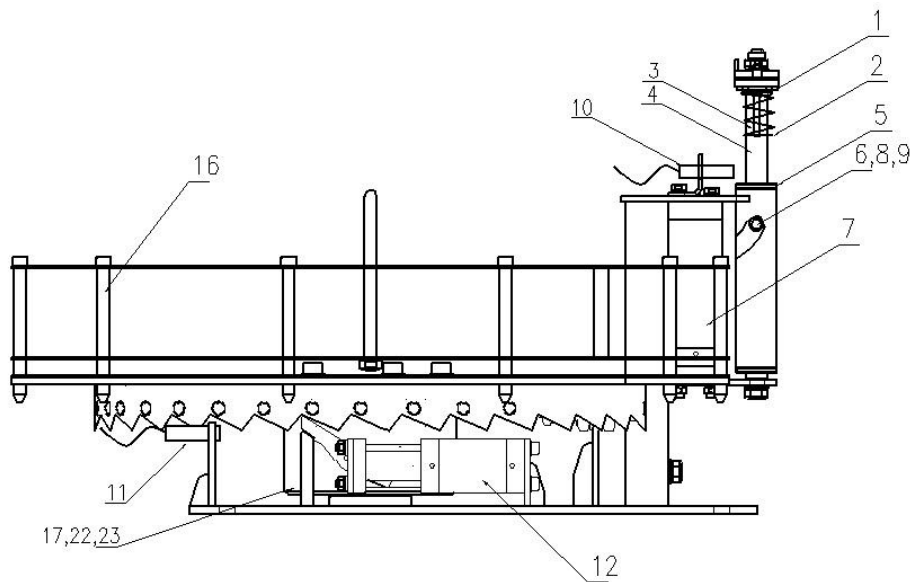

Wieniec 40

Nr rysunku:

Pozycja	Nazwa		Uwagi
1	Nakrętka iglicy	OMP.B.000.03.0	
2	Sprężyna iglicy pobieracza	C.216.140.0320.I	
3	Iglica	OMP.B.000.01.0	
4	Oś siłownika	OMP.B.301.06.0	
5	Tulejka	OMP.B.300.01.0	
6	Łożysko	SS685ZZ	
7	Siłownik komp.D 20x 70 d.dz.prow.		
8	Podkładka 5 A2-70	DIN 125	
9	Śruba imbusowa M5x15 A2-70	DIN 6912	
10	Czujnik indukcyjny M8 x 1 / 40 mm, 3mm	NO 24 VDC PNP	
11	Czujnik indukcyjny M12 x 1 / 60 mm 4mm	NO 24 VDC PNP	
12	Siłownik komp.D 20x 30 d.dz.prow.		
13	Język	OMP.B.110.02.0	
14	Sprężyna skrętna języka	G.090.100.0350.I	
15	Czujnik indukcyjny M12 x 1 / 60 mm 4mm	NO 24 VDC PNP	
16	Kosz magazyny butelek	OMP.B.200.00.0	
17	Piasta	OMP.B.100.05.0	
18	Nakrętka niska M12x1.5 A2-70	DIN 439	
19	Nakrętka niska M16x1.5 A2-70	DIN 439	
20	Śręt nierdzewny \varnothing 10	AISI 316 G 100	
21	Sprężyna A2-70	C.080.080.0320. I	
22	Łożysko	ozn. 6210-2RS	
23	Łożysko	ozn. 6208-2RS	



Wieniec 40

Nr rysunku:

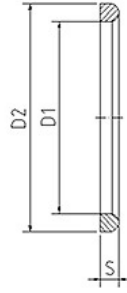

DN	D1	D2	S	Waga (kg)	MATERIAŁ
10	12	20	4,5	0,001	
15	18	26	4,5	0,002	
20	23	33	4,5	0,003	NBR
25	30	40	5,0	0,003	
32	36	46	5,0	0,004	EPDM
40	42	52	5,0	0,004	
50	54	64	5,0	0,005	SILIKON
65	71	81	5,0	0,006	
80	85	95	5,0	0,008	VITON
100	104	114	6,0	0,012	
125	130	142	7,0	0,018	TEFLON
150	155	167	7,0	0,023	
200	204	216	7,0	0,036	

Uszczelka DIN 11851

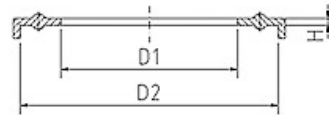

DN	D1	D2	H	Waga (kg)	MATERIAŁ
10	10,2	34	2,1	0,003	
15	16,2	34	2,1	0,002	
20	20,2	34	2,1	0,002	SILIKON
25	26,2	50,5	2,1	0,005	
32	32,2	50,5	2,1	0,004	EPDM
40	38,2	50,5	2,1	0,004	
50	50,2	64	2,1	0,005	VITON
65	66,2	91	2,1	0,012	
80	81,2	106	2,1	0,012	NBR
100	100,2	119	2,1	0,011	
125	125,2	155	2,1	0,014	TEFLON
150	150,2	183	2,1	0,018	
200	200,2	233,5	2,1	0,025	

Uszczelka złącza CLAMP – zgodnie z DIN 32676

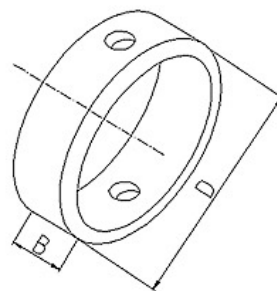

DN	B	D	Waga (kg)	MATERIAŁ
25	20	40	0,020	
32	20	48	0,030	SILIKON
40	21	54	0,050	
50	21	66	0,060	EPDM
65	22	84	0,070	
80	24	100	0,100	NBR
100	26	115	0,100	
125	30	151	0,250	VITON
150	30	175	0,270	

Uszczelnienie zaworu klapowego



Klucz hakowy

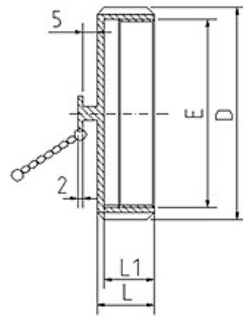

DN	D	L	L1	E	Waga (kg)
10	38	18	15	Rd 28 x 1/8"	0,12
15	44	18	15	Rd 34 x 1/8"	0,15
20	54	20	17	Rd 44 x 1/6"	0,19
25	63	21	18	Rd 52 x 1/6"	0,25
32	70	21	18	Rd 58 x 1/6"	0,29
40	78	21	18	Rd 65 x 1/6"	0,33
50	92	22	19	Rd 78 x 1/6"	0,46
65	112	25	21	Rd 95 x 1/6"	0,85
80	127	29	25	Rd 110 x 1/4"	1,11
100	148	31	26	Rd 130 x 1/4"	1,53
125	178	35	30	Rd 160 x 1/4"	2,12
150	210	40	34	Rd 190 x 1/4"	3,40
200	260	44	38	Rd 240 x 1/4"	4,75

Nakrętka zaślepiająca z łańcuszkiem

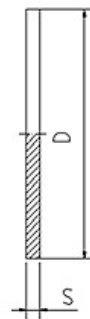

DN	D	S	Waga (kg)	MATERIAŁ
10	28	3	0,002	
15	34	3	0,003	
20	44	3	0,006	
25	52	3	0,010	NBR
32	58	3	0,011	
40	65	3	0,016	EPDM
50	78	3	0,021	
65	95	3	0,030	VITON
80	110	3	0,050	
100	130	3	0,080	TEFLON
125	160	3	0,125	
150	190	3	0,145	
200	240	3	0,180	

Uszczelka nakrętki zaślepiającej

W przypadku zamówienia należy podać rozmiar uszczelki DN z danej tabeli.

UWAGI PRODUCENTA:

1. Zamawiając część zamienną należy podać nr rysunku, pozycję zamawianego podzespołu lub jej nr katalogowy
2. Niektóre części zamienne wymagają podania dodatkowych parametrów takich jak, wymiar, średnicę itp.
3. W przypadku braku zamówionej części w magazynie WSK KROSNO, termin realizacji może ulec wydłużeniu.
4. Zamówienia prosimy kierować do Serwisu.
5. Zamówienia części bez podanego numeru katalogowego, nr rysunku i pozycji lub dokładnego opisu (typ, wymiar, rozmiar) nie będą realizowane.

Kontakt Centrala:

Telefon: +48 13 4374301

Fax: +48 13 4368861

Serwis Wydziału Cystern:

Telefon: + 48 607592220, +48 607592255

E-mail: serwis@wsk-krosno.pl

Dział Handlu:

Telefon: +48 13 4374 425426